

# CREATIVE HOUSE

GROUP OF COMPANIES

# CHS<sup>®</sup>

Creative House Scaffolding LLC

Sale . Hire . Contracts



*We Provide Ultimate*

# *Solutions!*

CORPORATE COMPANY

# PROFiLE

SMART. STRONG. SWIFT.

[www.chsdx.com](http://www.chsdx.com)

SCAFFOLDING | DESIGN | SUPPLY | APPLY

# CHS<sup>®</sup>

Creative House Scaffolding LLC

Sale . Hire . Contracts



A vertical red line on the left side of the page.

## TABLE OF CONTENT

About CHS .....	04
Licenses & Certificates .....	06
Organization Chart .....	07
Creative Lock System (Formwork) .....	08-11
Technical Data .....	12
Creative Ringlock System .....	13-17
CHS Design Systems .....	18
Creative Formwork .....	19-28
Creative Formwork Accessories .....	29
Aluminum Mobile Tower .....	30
Heavy Duty Mobile Tower .....	31
Castor Wheels .....	32
Creative Power Towers .....	33-37
Scaffold Pipes .....	39
Scaffold Wooden & Steel Boards .....	40
Ladder & Unit Beams .....	41
Scaffold Fittings .....	42-43
Scaffold Tools / Ancillary .....	44-45
Scaffold Subcontract Jobs .....	46
Project Photo Gallery .....	47-55
Corporate Clients .....	56
CHS Location & Contact .....	57

## WHO WE ARE?

**M/S Creative House Scaffolding (LLC)**, Dubai is a Limited Liability Company incorporated under the provisions of Commercial Companies Act 1984 (as amended) in the Emirates of Dubai. The company is operating in the emirate of Dubai by virtue of a commercial license by the department of economic development in Dubai (License # 542635). The registered office of the company is situated in the emirate of Dubai.



The company is headed by **Mr. Nasir Syed**, the Managing Director of the firm.

Under the leadership of **Mr. Nasir Syed**, **CHS** has managed to grow from a single division to a multi-faceted organization. Expansion & Growth plans were made possible through a philosophy & strategy of Customer Service & Compliance. Dynamic & skillful leadership, efficient management system & high level of transparency has led **CHS** to grow at a robust pace.

Engineered for  
Performance,  
**Designed for  
Simplicity &  
Speed...**





## Creative House Scaffolding LLC

Sale . Hire . Contracts

### ABOUT US

Established in 2003, **Creative House Scaffolding LLC (CHS)** has since gained a reputation for versatility & innovation in the field of scaffolding & formwork.

With services ranging from sale, hire & contracts, we at **CHS** have the know-how to meet customer challenges with ease. Our confidence lies in the quality & reliability of our services & we believe, in today's market, that's a force to be reckoned with.

For over **25 years**, **CHS** has built a reputation as a trusted leader in the scaffolding & formwork industry. Our team strikes the perfect balance between deep industry expertise & hands-on experience, allowing us to successfully serve a wide range of sectors - from construction, industrial, oil & gas (onshore & offshore), & power generation to shipyards & aviation.

Driven by a strong foundation of passion & dedication, every **CHS** team member is committed to delivering superior service & complete client satisfaction. Our operations consistently meet the highest levels of efficiency & product quality, aligning with the most rigorous international benchmarks.

This unwavering commitment has earned **CHS** prestigious certifications, including **ISO 9001:2015**, **ISO 14001:2015**, & **ISO 45001:2018**, reaffirming our position as an industry leader with global standards.



An acknowledgment of the passion,  
Dedication & integrity shared by every member at **CHS**

### CHS IS AN ORGANIZATION INSTILLED PASSION & DEDICATION

**Creative House Scaffolding** presents a high-performance Table Formwork System designed for fast, safe, & efficient slab construction. The system allows easy assembly, transport, & repositioning — even over obstacles—without removing props. Built for speed & simplicity, **CHS** delivers smarter solutions for modern construction needs.



Manpower

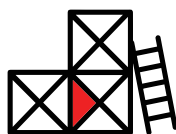

Supply, Fixing  
& Dismantling



Rental & Sale



Transportation



## ORGANIZATION CHART



**NASIR SYED**  
Managing Director



**MATHIYAS**  
Sales Director



**ALTHAF SHEIK**  
CFO

SCAFFOLDING & FORMWORK

OHTL DIVISION

DESIGN DEPARTMENT

MARKETING DEPARTMENT

FINANCE & ADMIN

STORES DEPARTMENT

OPERATIONS DEPARTMENT

IT DEPARTMENT



**Syed Tehseer**  
Sales Manager



**Mathiyas**  
OHTL Manager



**Amal Algammal**  
Design Manager (OHTL Division)



**Anas Mohammed**  
Design Manager



**Muhammad Fahad**  
Sr. Graphic Designer



**Arshakh**  
Senior Accountant



**Muneer**  
Yard Manager



**Muhammad Zakriya**  
Operations Manager



**Azeir**  
IT

Trading Division

Access Hire & Contract Division

Formwork Hire & Contract Division

Safety HSE



**Ayesha**  
Asst. Manager (Trading Division)



**Imaad**  
Asst. Manager



**Imtiyaz**  
Asst. Manager

Quality Control

ISO - MR



**Naufal Khan**  
Design Engineer



**Nihal Iqbal**  
Design Engineer



**Daniela Gonzalez**  
Content Writer



Video Editor



**Naeem**  
Accountant



**Gandhali Patil**  
Accountant



**Lloyd**  
Accountant



**Mohd. Ishal**  
Purchase Officer

Material Delivery Incharge

Forklift Drivers

Trailer & Pickup Drivers

Yard Labours

Logistic Dept.

Vehicle Repair & Maintenance

Mechanics

Camp Warden

Contract Costing Dept.

Site Supervisors

Site Supervisor

Safety Officers

Foremen

Scaffolders

Carpenters

*Where Organization...  
Meets Strength!*

## CREATIVE LOCK SYSTEM HORIZONTAL FORMWORK

### SCAFFOLDING CUPLOCK STANDARD

The CHS Cuplock Scaffolding Standard is made from 48.3 mm diameter X3.2mm thickness high tensile steel tube Q345. It is produce by a fixed bottom cup which is welded at 500mm intervals, with a captive moving top cup that can secure up to four components. These cups are the fixing points for the ledgers, transoms & ancillary items.

3.0 mtr.	14.80 kg
2.5 mtr.	12.40 kg
2.3 mtr.	11.40 kg
2.0 mtr.	10.00 kg
1.8 mtr.	9.00 kg
1.5 mtr.	7.90 kg
1.3 mtr.	6.50 kg
1.0 mtr.	5.00 kg

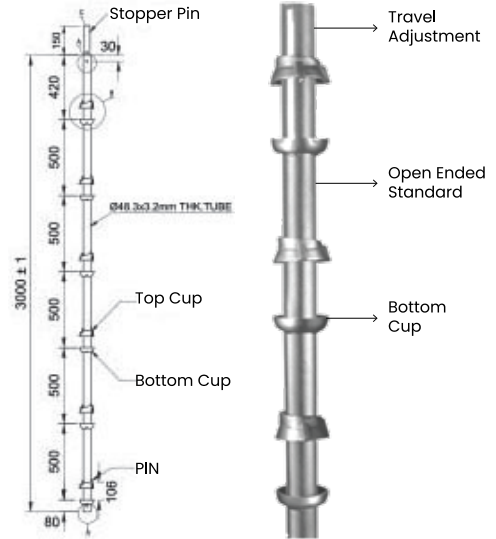

### LEDGER

As the basic component of Cuplock Scaffolding System, The CHS Cuplock Scaffolding Ledger is belong to horizontal members that form the ledgers and structural transoms of the CHS Cuplock Systems. It is welded 2 forged ledger blade ends that allowed to be completely quick to assemble into the Standard CUP points.

3.00 mtr	9.28 kg	1.20 mtr	4.09 kg
2.50 mtr	8.23 kg	1.10 mtr	3.77 kg
2.00 mtr	6.64 kg	1.00 mtr	3.46 kg
1.80 mtr	6.00 kg	0.90 mtr	3.14 kg
1.60 mtr	5.36 kg	0.80 mtr	2.82 kg
1.50 mtr	5.05 kg	0.70 mtr	2.50 kg
1.30 mtr	4.41 kg	0.60 mtr	2.18 kg
Material	Steel Tube		
Surface Treatment	Hot-dip Galvanized / Electro-glavanized		



### FACE BRACE SWIVEL

A horizontal scaffolding member designed with swivel connectors at both ends, allowing quick & secure attachment at various angles. Used to provide stability & support in scaffold structures.

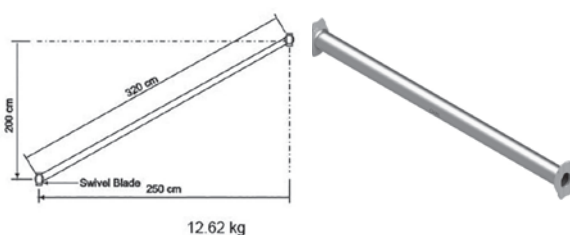

### INTERMEDIATE TRANSOM

They are used where scaffold boards require intermediate support between the span of 2 ledgers.

0.90 mtr	5.42 kg	1.30 mtr	6.84 kg
1.00 mtr	5.78 kg	1.60 mtr	7.91 kg
1.10 mtr	6.13 kg	1.80 mtr	8.62 kg
1.20 mtr	6.49 kg	2.50 mtr	11.11 kg



## BASE JACK

Base Jack are located in the bottom of the supporting scaffolding system, (cup lock scaffolding system, ring lock scaffolding system, kwikstage scaffolding system & also formwork system) Many workplaces are uneven, & scaffolding base jacks help to provide a safe & level working surface at a variety of working heights on the ground.

<b>Hollow Base Jack (0.38mm)</b>		
Length 0.65 mtr	Base 15 x 15	3.68 kg
Length 0.76 mtr	Base 15 x 15	4.05 kg
Length 0.86 mtr	Base 15 x 15	4.39 kg
<b>Solid Base Jack (0.36mm)</b>		
Length 0.86 mtr	Base 12 x 12	8.01 kg
<b>Solid Base Jack (0.32mm)</b>		
Length 0.65 mtr	Base 12 x 12	5.24 kg
Length 0.65 mtr	Base 15 x 15	5.60 kg
Length 0.76 mtr	Base 15 x 15	6.30 kg
Length 0.86 mtr	Base 15 x 15	6.93 kg
Compliance	British Standard 1139	
Finishes	MS Black / Galvanized	

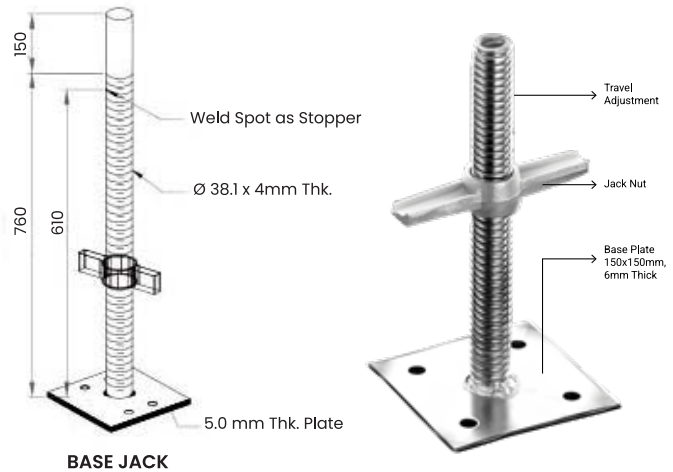

## ROCKING BASE JACK

<b>Hollow Rocking Base Jack (38mm)</b>		
Length 65 cm	Base 15 x 15	4.90kg
<b>Hollow Rocking Base Jack (36mm)</b>		
Length 65 cm	Base 15 x 15	7.91 kg
<b>Hollow Rocking Base Jack (32mm)</b>		
Length 68 cm	Base 15 x 15	6.78kg
Finishes	Painted Grey Finish	
D/F Jack Handle		
Plate	15 x 15 cm (with Holes)	

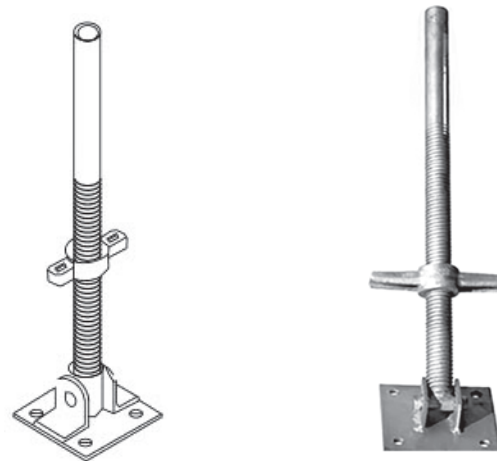

## BASE PLATE

12 x 12 cm	Rod 10 mm	0.77 kg
15 x 15 cm	Rod 10 mm	1.13 kg
15 x 15 cm	Rod 25 mm	1.71 kg
Finishes	Painted Grey Finish	
Plate	15 x 15 cm (with Holes)	

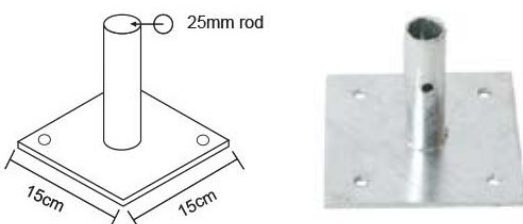

## ROCKING BASE PLATE

Height	20 cm	2.45 kg
Finishes	Painted Grey Finish	
Plate	15 x 15 cm (with Holes)	

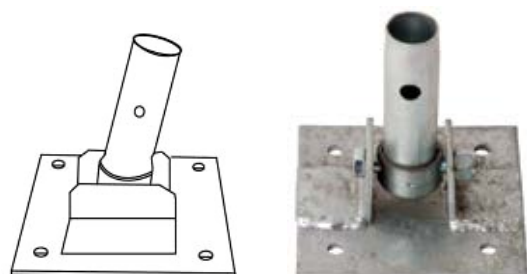

## CREATIVE LOCK SYSTEM HORIZONTAL FORMWORK

### UNIVERSAL JACK (with hole)

The adjustable jack provides a method of adjustment which can be used at either the top or bottom of a scaffold support structure. It is used in conjunction with Forkheads & adaptors & can accept the full loading capability of Cuplock System when fully braced.

38 mm Hollow (with Hole)		
Length	0.65 mtr	2.65 kg
Length	0.76 mtr	5.25 kg

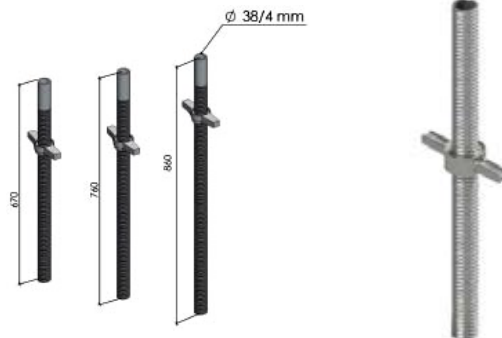

### FORK HEAD

38 mm Hollow 38H/15	Size: H10 x W7 x L15	3.38 kg
48.3 mm Hollow 42H/12	Size: H10 x W7 x L15	3.33 kg

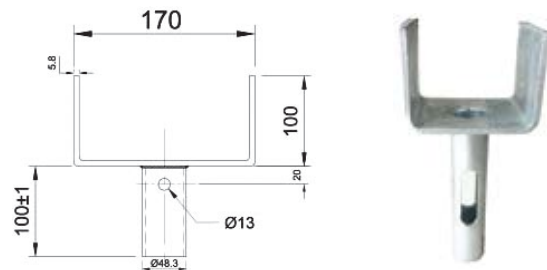

### ADJUSTABLE U-HEAD

A steel scaffolding accessory for supporting beams & formwork, with a threaded rod for precise height adjustment in construction.

H x W H L	5.80 kg
Length	76 cm
Size	10 x 15 x 17

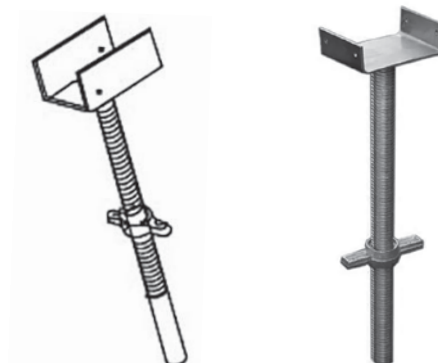

### SCAFFOLDING RINGLOCK

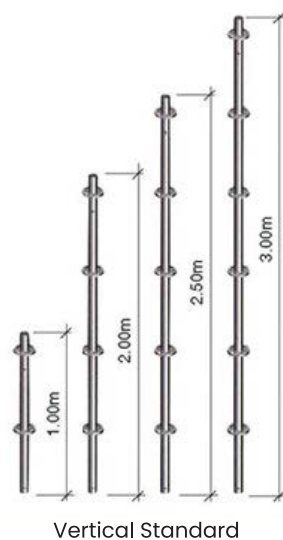

## SPIGOT CONNECTOR

Round Tubes Spigot Connector	0.87 kg (with washer)
Round Tubes Spigot Connector	0.96 kg (with bolts)
Square Tubes Spigot Connector	0.70 kg (with washer)
Square Tubes Spigot Connector	0.68 kg (with bolts)

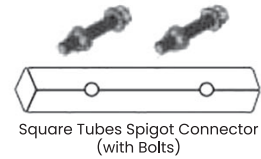
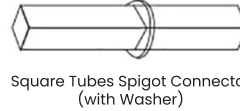
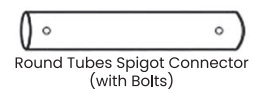

## CANTILEVER BEAM FRAME

1.50 mtr.	19.43 kg
1.00 mtr.	16.35 kg
Finish	Painted
Available Sizes	L 1.5 & 1 meter

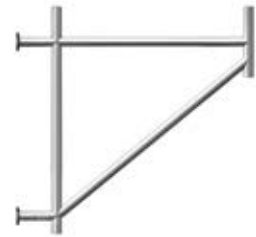
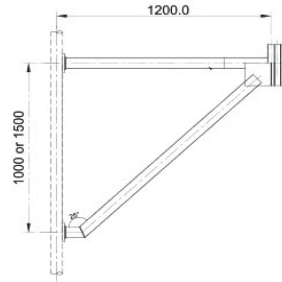

## CANTILEVER FRAME

1.50 mtr.	16.99 kg
1.00 mtr.	15.69 kg
Finish	Painted
Available Sizes	L 1.5 & 1 meter

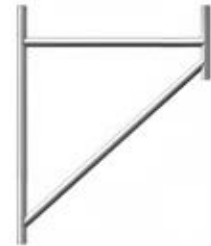
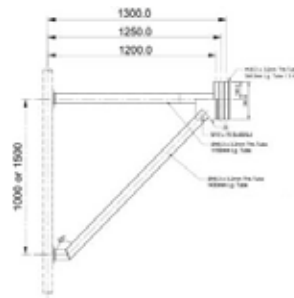

## BEAM BRACKET

The Beam Brackets are capable of receiving adjustable jacks for reaching the beam bottom level. To support Beams, eliminating the need of extra rows of support under the Beams.

1.50 mtr	6.49 kg
1.00 mtr	4.72 kg
Available Sizes	L: 1.59 m, L: 1.00 m

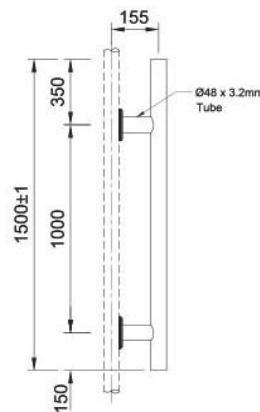

## HOP-UP BRACKET

Genlok provides 2 & 3 board width hop-up brackets to enable work to take place away from the main scaffold run.

3 Boards	7.68 kg
2 Boards	6.25 kg
Finishes	Painted

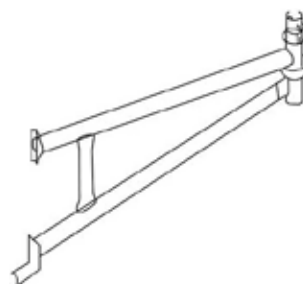

## CREATIVE LOCK TECHNICAL DATA

### VERTICAL (STANDARDS)

Standards are manufactured from 48.3 mm O.D. steel tubes with different housing sets (according to the features of each standard joints), at certain intervals. Standards are made available in open ended versions, or with welder spigots. Standard tubes of mild conform to BS 1139, supplied painted or galvanized finish.

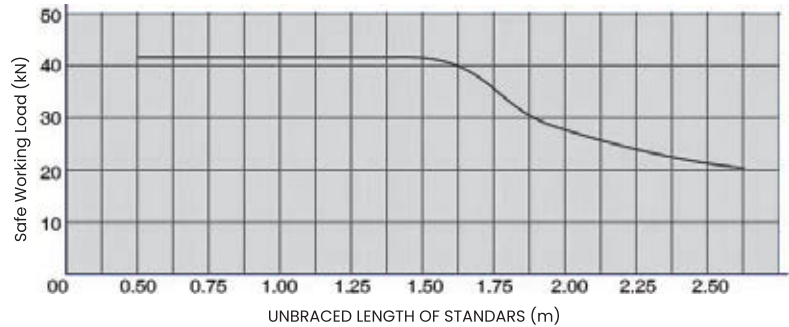

The figure below illustrate the maximum permissible loading on standards. This figure incorporate factors of safety on failure of 2.0

### BASE JACK & UNIVERSAL JACK

The 57 KN capacity galvanized jack has an adjustment range of over 45 cm. It is manufactured from 38mm outside diameter steel t s with a rolled / cut thread.

The jack can be used either at top or the bottom vertical (standard), so the reasonable portion of the jack will always remain inside the vertical for safety.

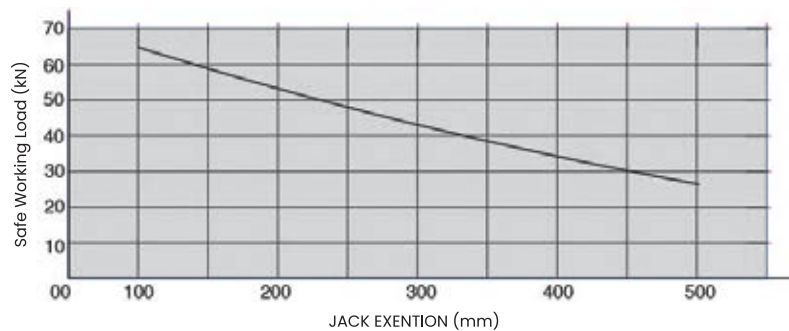

The figure below illustrate the safe working load on tubular Jacks. The data incorporates factors of safety on failure of 2.75

### HORIZNONTAL (LEDGERS)

Horizontal (S.W.L)			
Ledger size (m)	Central Point Load (kn)	U.D.I (kn/M)	2 Equally Spaced Point Load (kn)
2.5	1.71	2.7	1.29 (each)
1.8	3.4	-	-
1.6	3.52	-	-
1.2	3.7	-	-
0.9	4.8	-	-

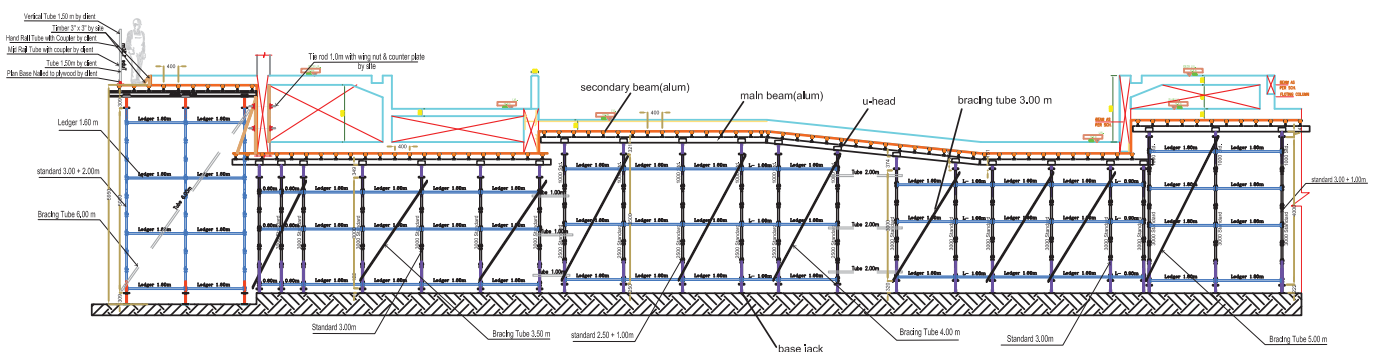
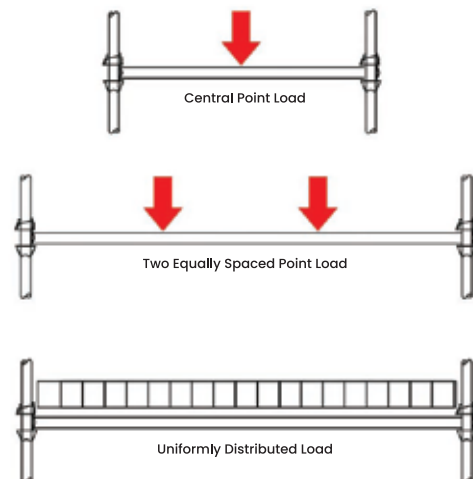

# CHS

Creative House Scaffolding LLC

Sale . Hire . Contracts

## CREATIVE RINGLOCK SYSTEM

CREATIVE

## RINGLOCK SYSTEM (B48)

Type-B, National Standard Scaffolding

### CHS RINGLOCK STANDARD

**B48 Ringlock Standard**, made of Q355B material, with a steel pipe diameter of 48.3mm & a wall thickness of 3.2mm. There are 8 holes on the ring, 4 small holes connected to the ringlock ledger, & 4 large holes connected to the ringlock diagonal brace. The ring lock equal spacing every 500mm, the upper end is 250mm, & the lower end is 250mm. The connection method is sleeve connection. It can be used in the construction of bridges, large factories, & construction of internal & external operating frames for ordinary building. Fast erection speed, safety & efficiency.

ITEMS	NAME	SPEC	LENGTH(MM)	WEIGHT(KG)
1	B48 Ringlock Standard	LG-300	3000	15.36
2	B48 Ringlock Standard	LG-250	2500	12.95
3	B48 Ringlock Standard	LG-200	2000	10.60
4	B48 Ringlock Standard	LG-150	1500	8.22
5	B48 Ringlock Standard	LG-100	1000	5.84
6	B48 Ringlock Standard	LG-50	500	3.47
7	B48 Ringlock Standard	JZ-35	350	1.87
8	B48 Ringlock Standard	LG-25	250	1.94

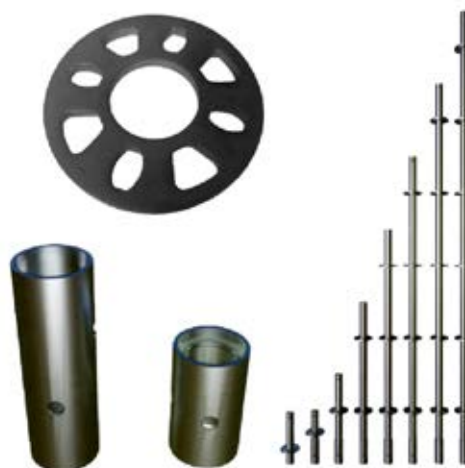

### CHS RINGLOCK LEDGER

**B48 Ringlock Ledger** made of Q235B material, with a steel pipe diameter of 48.3mm & a wall thickness of 2.75mm. 2 buckle joints are welded at both ends of the steel pipe, & a pin plate is riveted inside each buckle joint. It is the transverse force-bearing component of the scaffolding system, & the length modulus is 30CM.

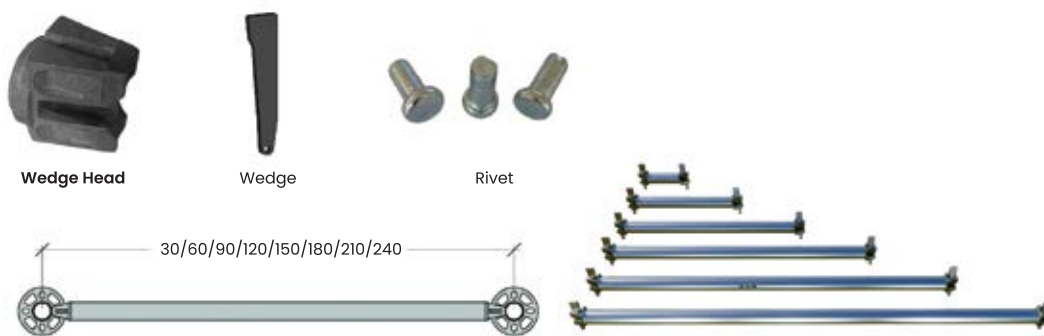

ITEMS	NAME	SPEC	LENGTH (MM)	WEIGHT (KG)
1	Ringlock Ledger	SPG-30	251.7	1.45
2	Ringlock Ledger	SPG-60	551.7	2.41
3	Ringlock Ledger	SPG-90	851.7	3.37
4	Ringlock Ledger	SPG-120	1151.7	4.33
5	Ringlock Ledger	SPG-150	1451.7	5.29
6	Ringlock Ledger	SPG-180	1751.7	6.25
7	Ringlock Ledger	SPG-210	2051.7	6.89
8	Ringlock Ledger	SPG-240	2351.7	8.17

CREATIVE

## RINGLOCK SYSTEM (Z60)

Type-Z, National Standard Scaffolding

### CHS RINGLOCK STANDARD

The Z60 series ringlock scaffolding is made of Q355B material, with a steel pipe diameter of 60.3mm & a wall thickness of 3.2mm. The disc spacing module is 500mm, with an upper end of 100mm and a lower end of 400mm connected internally. It has a high bearing capacity & can be used in construction environments with large loads such as bridges, large factories, & ordinary buildings.

ITEMS	NAME	SPEC	LENGTH(MM)	WEIGHT(KG)
1	Z60 Ringlock Standard	LG-200	200	13.22
2	Z60 Ringlock Standard	LG-150	150	10.24
3	Z60 Ringlock Standard	LG-100	100	7.26
4	Z60 Ringlock Standard	LG-50	50	3.63
5	Z60 Ringlock Standard	JZ-20	20	2.23

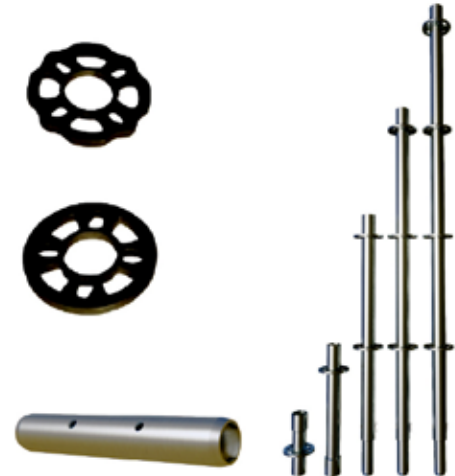

### CHS HORIZONTAL RINGLOCK LEDGER

**Z60 CHS Horizontal Ringlock Ledger** The national standard Z60 series horizontal ledger is made of Q235B material, with a steel pipe diameter of 48.3mm and a wall thickness of 2.75mm. The steel pipe is welded with 2 buckle joints at both ends, which are fastened together, A pin plate is riveted inside the head, which is the transverse load-bearing component of the scaffolding system, with a length modulus of 30cm.

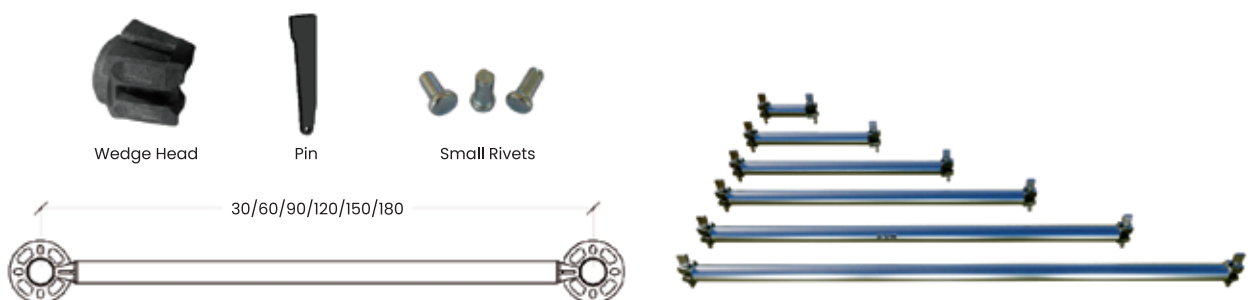

ITEMS	NAME	SPEC	LENGTH (MM)	WEIGHT (KG)
1	Ringlock Ledger	SPG-30	239.7	1.44
2	Ringlock Ledger	SPG-60	539.7	2.39
3	Ringlock Ledger	SPG-90	839.7	3.35
4	Ringlock Ledger	SPG-120	1139.7	4.31
5	Ringlock Ledger	SPG-150	1439.7	5.27
6	Ringlock Ledger	SPG-180	1739.7	6.23
7	Ringlock Ledger	SPG-210	2039.7	7.19
8	Ringlock Ledger	SPG-240	2339.7	8.15

## | CHS RINGLOCK DIAGONAL BRACE (B48)

B48 ringlock diagonal brace are made of Q195 material, with a steel pipe diameter of 42mm & a wall thickness of 2.75mm. Both ends of the steel pipe are profiled & riveted with an oblique head, & a pin plate is riveted inside the oblique head. They are diagonal force-bearing components of the scaffolding system. The height direction is mainly 150/200cm, & the width direction L is based on the ringlock ledger. The modulus is multiples of 30CM.



ITEMS	NAME	SPEC	LENGTH	WEIGHT	NAME	SPEC	LENGTH	WEIGHT
1	Vertical diagonal brace	SXXG-60x150	1606 mm	5.42 kg.	Ringlock diagonal brace	SXXG-60*200	-	-
2	Vertical diagonal brace	SXXG-90x150	1712 mm	5.70 kg.	Ringlock diagonal brace	SXXG-90*200	2174 mm	6.94 kg.
3	Vertical diagonal brace	SXXG-120x150	1861 mm	6.10 kg.	Ringlock diagonal brace	SXXG-120*200	2293 mm	7.26 kg.
4	Vertical diagonal brace	SXXG-150x150	2045 mm	6.59 kg.	Ringlock diagonal brace	SXXG-150*200	2444 mm	7.66 kg.
5	Vertical diagonal brace	SXXG-180x150	2254 mm	7.15 kg.	Ringlock diagonal brace	SXXG-180*200	2621 mm	8.14 kg.
6	Vertical diagonal brace	SXXG-210x150	2483 mm	7.77 kg.	Ringlock diagonal brace	SXXG-210*200	2819 mm	8.67 kg.
7	Vertical diagonal brace	SXXG-240x150	2726 mm	8.42 kg.	Ringlock diagonal brace	SXXG-240*200	3035 mm	9.25 kg.

## | CHS RINGLOCK DIAGONAL BRACE (Z60)

The Z60 series vertical ringlock diagonal brace is made of Q195 material, with a steel pipe diameter of 42mm & a wall thickness of 2.75mm. Both ends of the steel pipe are pressure treated, with 1 diagonal head riveted & 1 pin plate riveted inside the diagonal head. It is a diagonal load-bearing component of the scaffolding system, with a height direction of 150cm & a width direction based on horizontal ringlock ledger.

The module is Multiply by 30 cm.

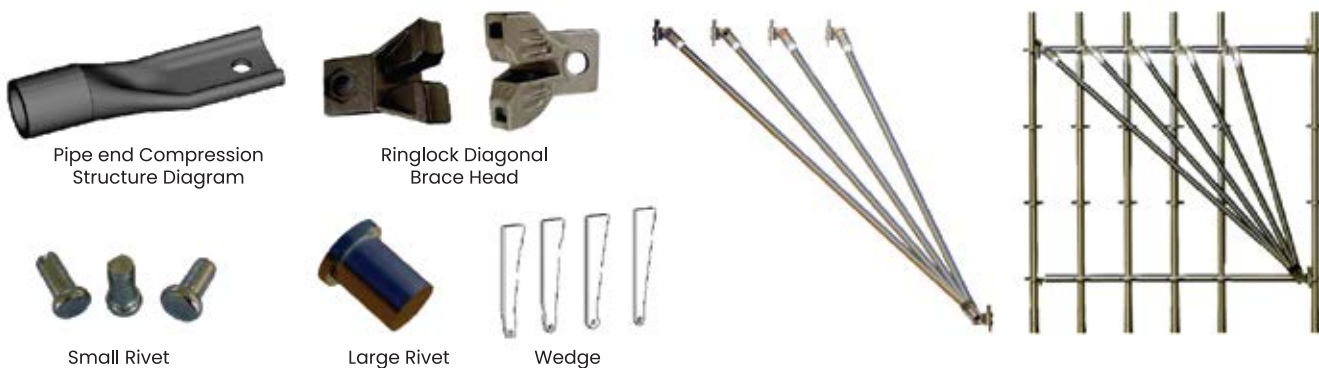

ITEMS	NAME	SPEC	LENGTH (mm)	WEIGHT (kg.)
1	Vertical Diagonal Brace	SXXG-60x150	1606	5.42
2	Vertical Diagonal Brace	SXXG-90x150	1712	5.70
3	Vertical Diagonal Brace	SXXG-120x150	1861	6.10
4	Vertical Diagonal Brace	SXXG-150x150	2045	6.59
5	Vertical Diagonal Brace	SXXG-180x150	2254	7.15

**EXPLANATION:** The length of steel pipes may vary depending on the structure of the fittings. Please refer to the processing drawing for details.

CREATIVE EUROPEAN STANDARD

## RINGLOCK SCAFFOLDING (B48)

The B48 series ringlock scaffolding is made of Q355B material, with a steel pipe diameter of 48.3mm & a wall thickness of 3.2mm. There are 8 hole connection holes on the ringlock, 4 small holes connected to horizontal ledgers, & 4 large holes connected to vertical diagonal brace. The spacing module of the disc is 500mm, with an upper end of 250mm & a lower end of 250mm connected by an outer jacket. It can be used in the construction of bridges, large factories, ordinary building internal & external operating frames, with high bearing capacity, fast erection speed, safety & efficiency.



ITEMS	NAME	SPEC	LENGTH (mm)	WEIGHT (kg.)
1	Ringlock Standard	LG-400	4000	19.4
2	Ringlock Standard	LG-300	3000	14.65
3	Ringlock Standard	LG-250	2500	12.18
4	Ringlock Standard	LG-200	2000	9.78
5	Ringlock Standard	LG-150	1500	7.34
6	Ringlock Standard	LG-100	1000	4.90
7	Ringlock Standard	LG-50	500	2.48
8	Ringlock Standard	LG-15	150	1.94



### REMARKS:

B48 Ringlock scaffolding system have many kinds of materials, structures & processing method, All can be customized. At the same time, we provide customized logo printing on product accessories to enhance the brand value of your products.

## CHS DESIGN SYSTEMS

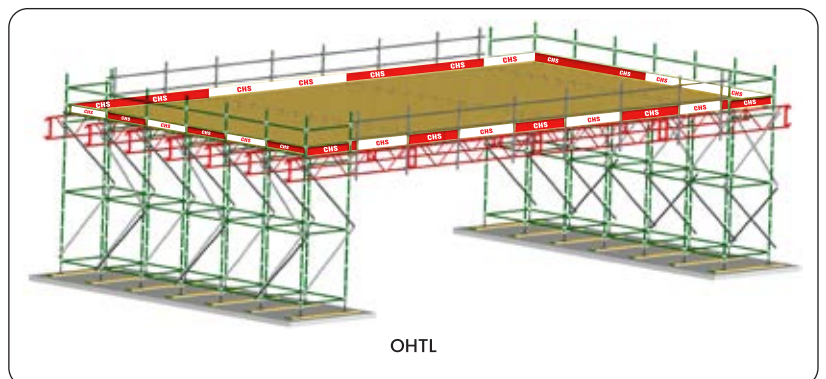
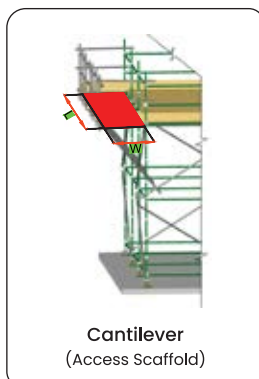
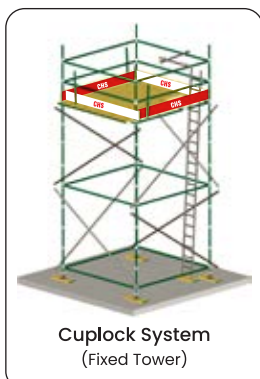
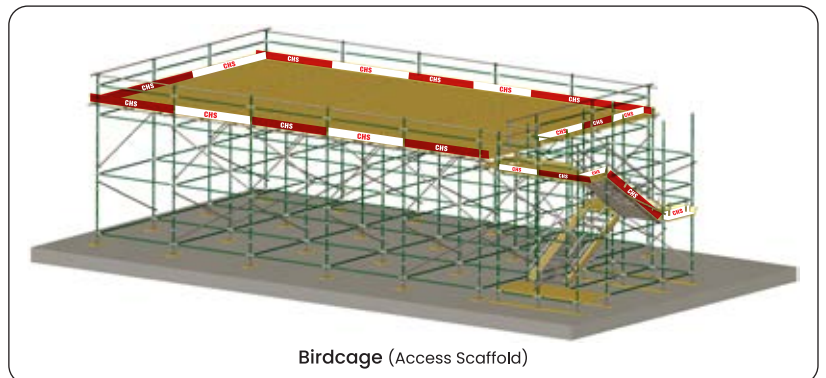
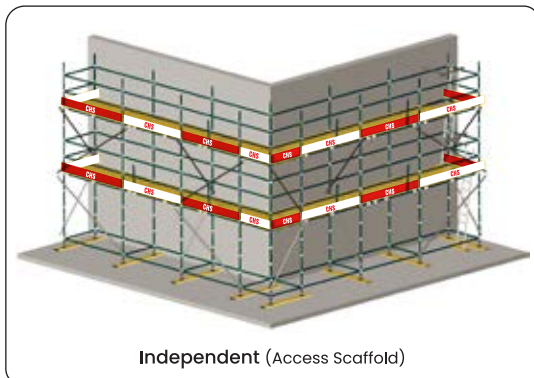
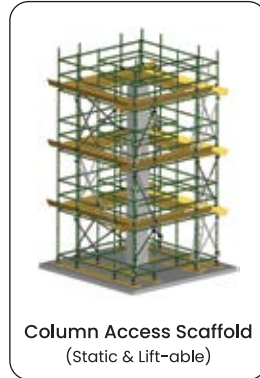
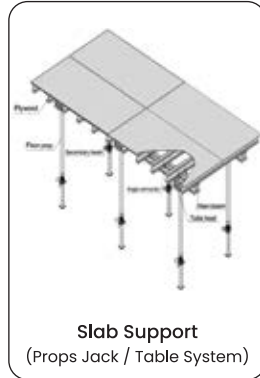
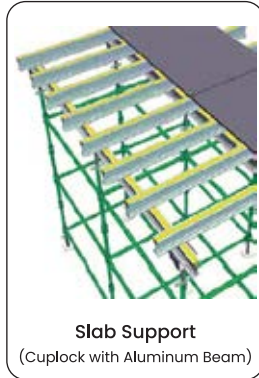

CONTRACT | DESIGN | SUPPLY | INSTALLATION

# CHS

Creative House Scaffolding LLC

Sale . Hire . Contracts

## CREATIVE TABLE FORMWORK SYSTEM SMART. STRONG. SWIFT.

*Organization Instilled with  
Passion & Dedication!*

## CREATIVE FORMWORK

### *Innovative Simplicity. Intelligent Strength.*

At **Creative House Scaffolding**, our Table Formwork System is a modern & efficient solution for slab construction. Developed using standard formwork components, this system is designed for simplicity, speed, & strength, making it ideal for a wide range of forming & support applications.

The table formwork is built using H20 timber girders or S150/T150 aluminum girders, offering versatility in decking configurations. It can be easily transported, assembled, dismantled, & reused, allowing for optimized labor efficiency & fast construction cycles.



Our system is highly flexible - tables can either be delivered pre-assembled to the site or assembled quickly on-site to suit different project logistics. The design features a innovative uniquely engineered table head, which allows quick attachment of props to the primary girder. This mechanism enables the table unit to be lifted & stored compactly, saving space & time during transport & on-site staging.

One of the standout features of **CHS** Table Formwork is its ability to pass over construction obstacles (such as upstand beams or parapets) without removing the props, minimizing downtime & simplifying repositioning.

With **CHS**, you're choosing a smarter way to build - one that delivers speed, safety, & consistency on every level of your construction project.

## SMART ADVANTAGE



Quick  
Assembly

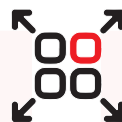

Easy  
Dismantling



Compact  
Transport



Reusable  
Components



Precision  
Engineering



Cost-efficient

## ADVANTAGES:

- PU-bonded beam end protects against moisture penetration & does not splinter
- Durable due to an one-piece PU-bonded end of the beam
- Made in Austria – exclusively available from specialised traders
- All beam flanges are proof-loaded

Form-on smart BEAM plus 20P	PU	KG	Art No.
Form-on smart BEAM plus 20P 180	100	9.4	620142000
Form-on smart BEAM plus 20P 245	100	12.7	620143000
Form-on smart BEAM plus 20P 265	100	13.8	620144000
Form-on smart BEAM plus 20P 290	100	15.1	620145000
Form-on smart BEAM plus 20P 330	100	17.2	620146000
Form-on smart BEAM plus 20P 360	100	18.7	620147000
Form-on smart BEAM plus 20P 390	100	20.3	620148000
Form-on smart BEAM plus 20P 450	100	23.4	620149000
Form-on smart BEAM plus 20P 490	100	25.5	620150000
Form-on smart BEAM plus 20P 590	60	30.7	620151000



## TECHNICAL SPECIFICATIONS:

Web	: height = 20 cm		
Flange	: height = 4.0 cm , width = 8.0 cm		
Moment (M)	: 5 kNm	Shear Force (Q):	11 kN
Regidity (Ex J)	: 450 kNm2	Certification	: EN 13377

## EXAMPLE:

- > Floor thickness : 20 cm
- > Secondary beam spacing : 0.75 m
- > Equals primary beam spacing as per Table 1 : 2.61 m |
- > Select primary beam spacing  $\leq$  2.61 in Table 2 : (=2.50 m)
- > Permissible prop spacing at 20cm floor thickness in Table 2 : 1.19 m

## H2O BEAM

- H2O beam : Formwork timber Beam is a solid Beam used for concrete formwork construction.
- Webs made : 3-Ply laminated solid wood, all-climate use.
- Beam height : 200 mm & available in different standard lengths.
- Chords made: Superior quality smoothly surfaced & slightly chamfered.



## TECHNICAL SPECIFICATIONS:

• Permissible bending moment (M)	=	0.50 t.m
• Permissible shear force (Q)	=	1.10 t
• Section modulus (Z)	=	461 cm <sup>3</sup>
• Geometrical moment on inertia (I)	=	4613 cm <sup>4</sup>

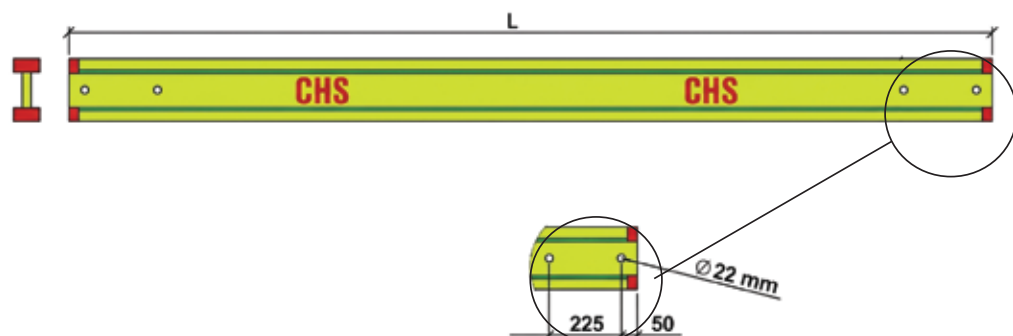
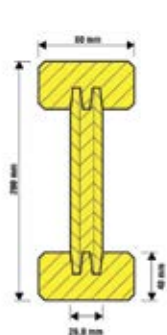

## CREATIVE FORMWORK

### S-150 ALUMINIUM BEAM

#### TECHNICAL SPECIFICATIONS:

• Permissible bending moment (M)	=	0.77 t.m
• Permissible shear force (t)	=	4.00 t
• Section modulus (Z)	=	51.70 cm <sup>3</sup>
• Geometrical moment on inertia (I)	=	389.70 cm <sup>4</sup>

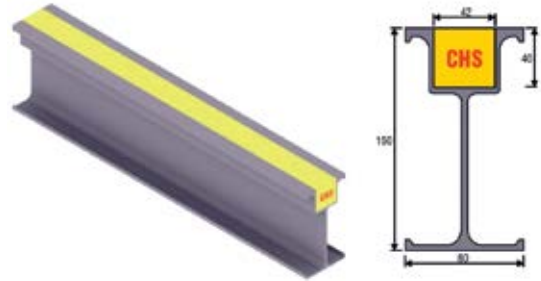

### T-150 ALUMINIUM BEAM

#### TECHNICAL SPECIFICATIONS:

• Permissible bending moment (M)	=	0.98 t.m
• Permissible shear force (t)	=	8.00 t
• Section modulus (Z)	=	65.82 cm <sup>3</sup>
• Geometrical moment on inertia (I)	=	460.7 cm <sup>4</sup>

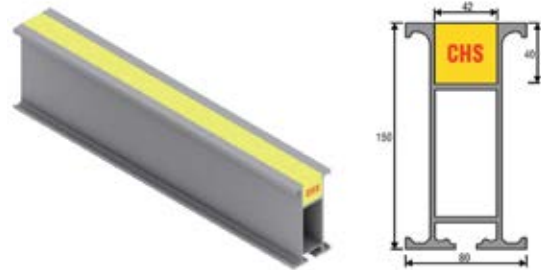
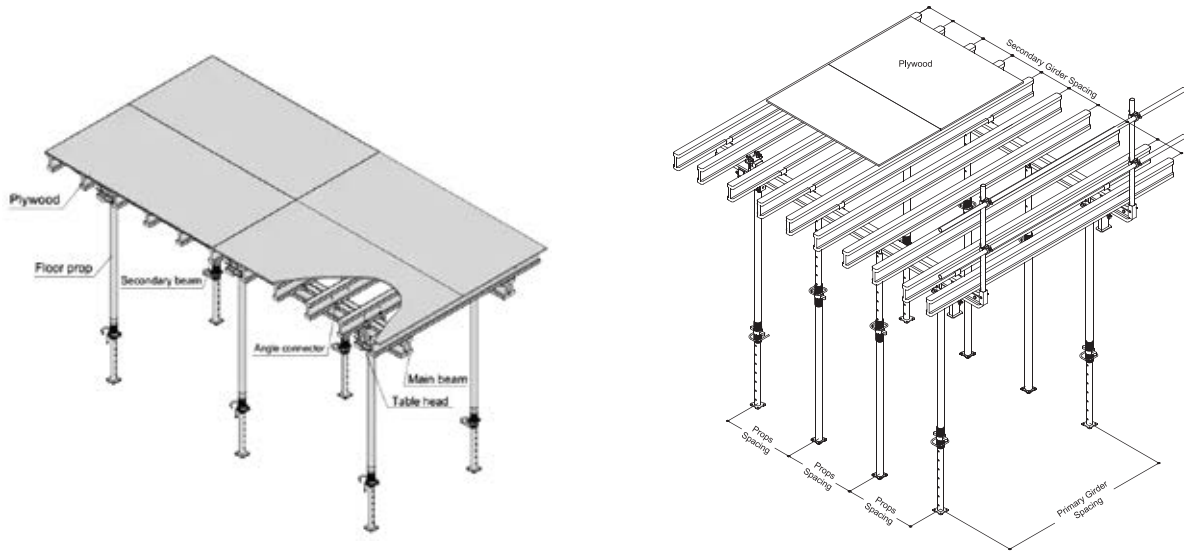

TABLE 1		TABLE 2													
Floor Thickness (cm)	Floor Load* (kN/m <sup>2</sup> )	Max. perm. primary beam spacing (m) for secondary beam spacing (m) of				Max. perm. prop spacing (m) for selected secondary beam spacing (m) of									
		0.500	0.625	0.667	0.750	1.00	1.25	1.50	1.75	2.00	2.25	2.50	2.75	3.00	3.50
10	4.3	3.69	3.43	3.35	3.22	2.93	2.72	2.50	2.32	2.17	2.04	1.88	1.71	1.57	1.34
12	4.7	3.49	3.24	3.17	3.05	2.77	2.57	2.37	2.20	2.05	1.87	1.69	1.53	1.41	-
14	5.2	3.33	3.09	3.03	2.91	2.65	2.46	2.26	2.09	1.91	1.70	1.53	1.39	1.27	-
16	5.7	3.20	2.97	2.91	2.79	2.54	2.36	2.16	2.00	1.75	1.55	1.40	1.27	1.16	-
18	6.2	3.08	2.86	2.80	2.69	2.45	2.27	2.07	1.84	1.61	1.43	1.29	1.17	-	-
20	6.7	2.98	2.77	2.71	2.61	2.37	2.18	1.99	1.70	1.49	1.33	1.19	1.08	-	-
22	7.2	2.90	2.69	2.63	2.53	2.30	2.11	1.85	1.59	1.39	1.24	1.11	1.01	-	-
24	7.7	2.82	2.61	2.56	2.46	2.24	2.04	1.73	1.49	1.30	1.16	1.04	0.95	-	-
26	8.2	2.75	2.55	2.49	2.40	2.18	1.96	1.63	1.40	1.22	1.09	0.98	-	-	-
28	8.7	2.68	2.49	2.44	2.34	2.13	1.85	1.54	1.32	1.15	1.03	0.92	-	-	-
30	9.2	2.62	2.44	2.38	2.29	2.08	1.75	1.46	1.25	1.09	0.97	0.87	-	-	-
35	10.5	2.50	2.32	2.27	2.18	1.91	1.52	1.27	1.09	0.95	0.85	-	-	-	-

\* Based on EN 12812, numbers refer to solid concrete floor slabs with live loads of 0.75 kN/m<sup>2</sup> & min. variable loads of 10% min. 0.75 N/m but not to exceed 1.75 kN/m (with 25 kN/m<sup>3</sup> fresh concrete slab bulk density). The mid-gan deflection hacheer limited to V500. Significantly lower floor loads are produced in hollow floor slabs.

## STANDARD UNITS OF TABLE FORMWORK



## HD PROP

### TECHNICAL SPECIFICATIONS:

- Internal tube with diameter 63.00 mm with thickness = 4mm steel grade 37.
- Prop locking nut to fix & fine adjustment of internal tube.
- Prop locking pin supporting external with internal tube & rested on prop nut.

TYPE	30KN	20KN	20KN
Description	CEP 350	CEP 400	CEP 550
Size	3.50	4.00	5.50

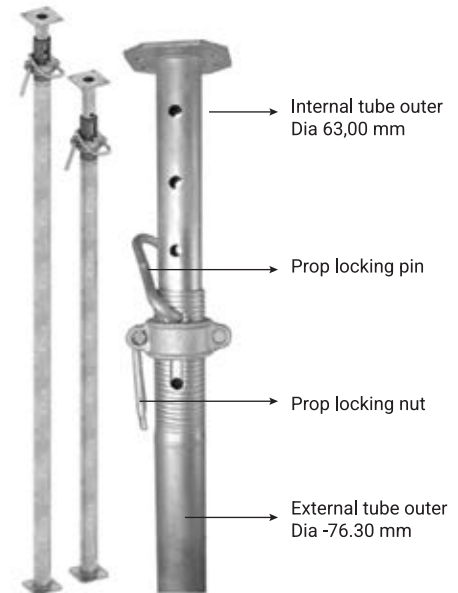

## PUSHPULL PROP (PAINTED & GALVANIZED)

PUSH PULL PROP	SIZES
GI / Painted (Full Set)	1-1.4, 2.2-3.4
GI / Painted (Single)	1-1.4
	2.2-3.4
	2.5-4
<b>PUSH PULL HEAD</b>	-
GI / Painted	-
<b>DOUBLE BASE PLATE</b>	-
GI / Painted	-
Revit Pin	-

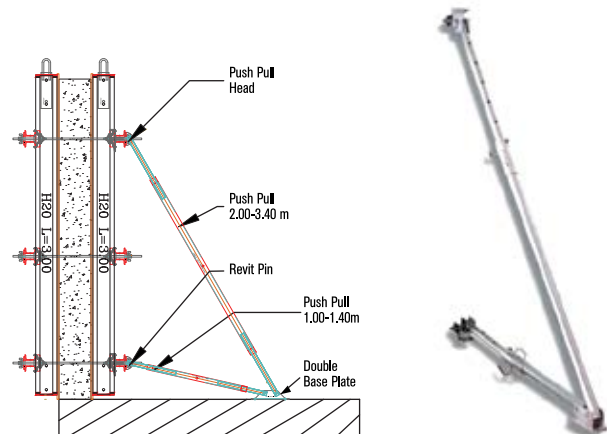

## CREATIVE FORMWORK

### STEEL WALER

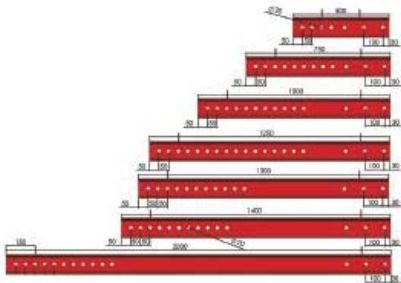

### STEEL WALER SPLICE



### LIFTING EYE



### TOP-SO CORNER CONNECTION

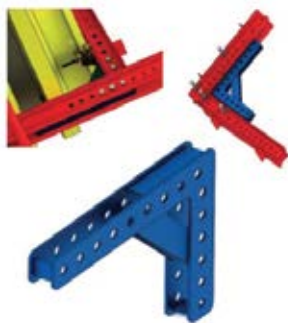

### T-SPLICE

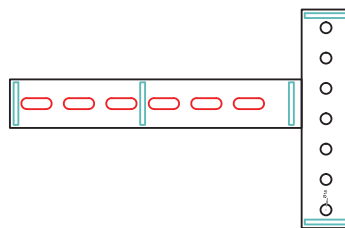

### ACCESS BRACKET



### HEAD PLATE

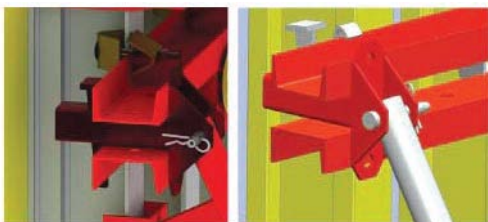

### DOUBLE BASE PLATE



### DRAWINGS

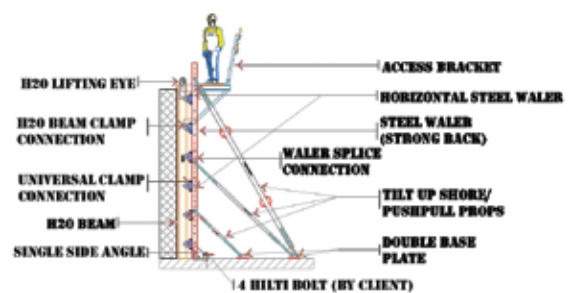
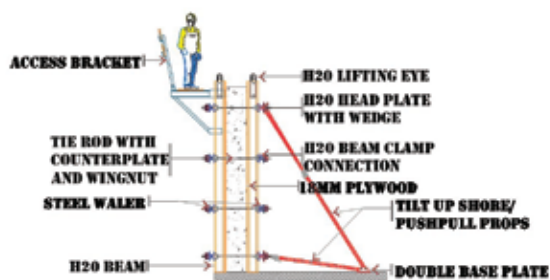

## | H20 EXTENSION SPLICE

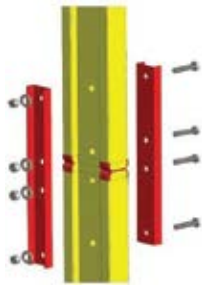

**H20 Extension Splice** is used for extending panel, it forms connection. between individual beams & produces tension & compression resistant, rigid, aligned & offset force joint between beams & panels.

The existing holes at the end of the beam can be used for bolt connection.

## | UNIVERSAL ANGLE TIE

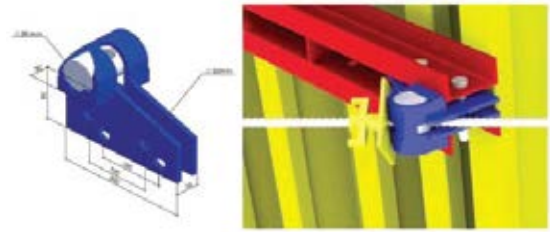

For clamping the corner panels together.

Using with tie rod for fixing outside corners with needed angle.

The angle range between tie rod & Steel Waler from 23 ° to 64 °.

## | H20 BEAM CLAMPS

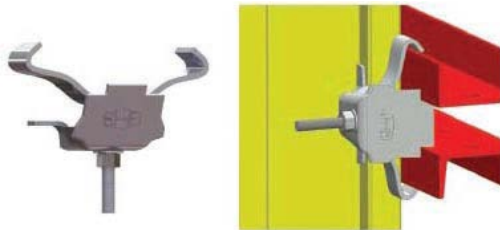

Flange Clamp

Use reliably to connect the **H20** beam to the Steel Waler at any required level, of Steel Waler, to ensure that the angle between **H20** Beams & Steel Waler is 90°.

## | UNIVERSAL CLAMP



## | SHIFTING TROLLEY

The Shifting Trolley is used for the overall transporation of the formwork in the horizontal direction.

### HEIGHT:

Standard Device	
H (min)	= 1750 mm
H (max)	= 3250 mm

### Standard device with an attached frame

H (min)	= 2500 mm
H (max)	= 3900mm

### BEARING LOAD:

Standard Device	15~20KN
Standard device with an attached frame	: 11KN

### STANDARD DEVICE

Weight : 516.31 Kg.

### ATTACHED FRAME

Weight : 72.17Kg.

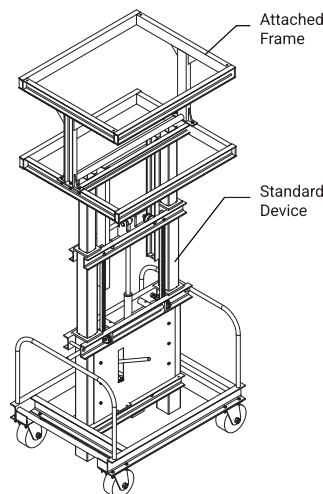

Standard Device with Attached Frame



## CREATIVE FORMWORK

### LIFTING FORK

The lifting fork is used for lifting of the table unit, which allows the overall transportation of the large area table, greatly improving the work efficiency & saving time.

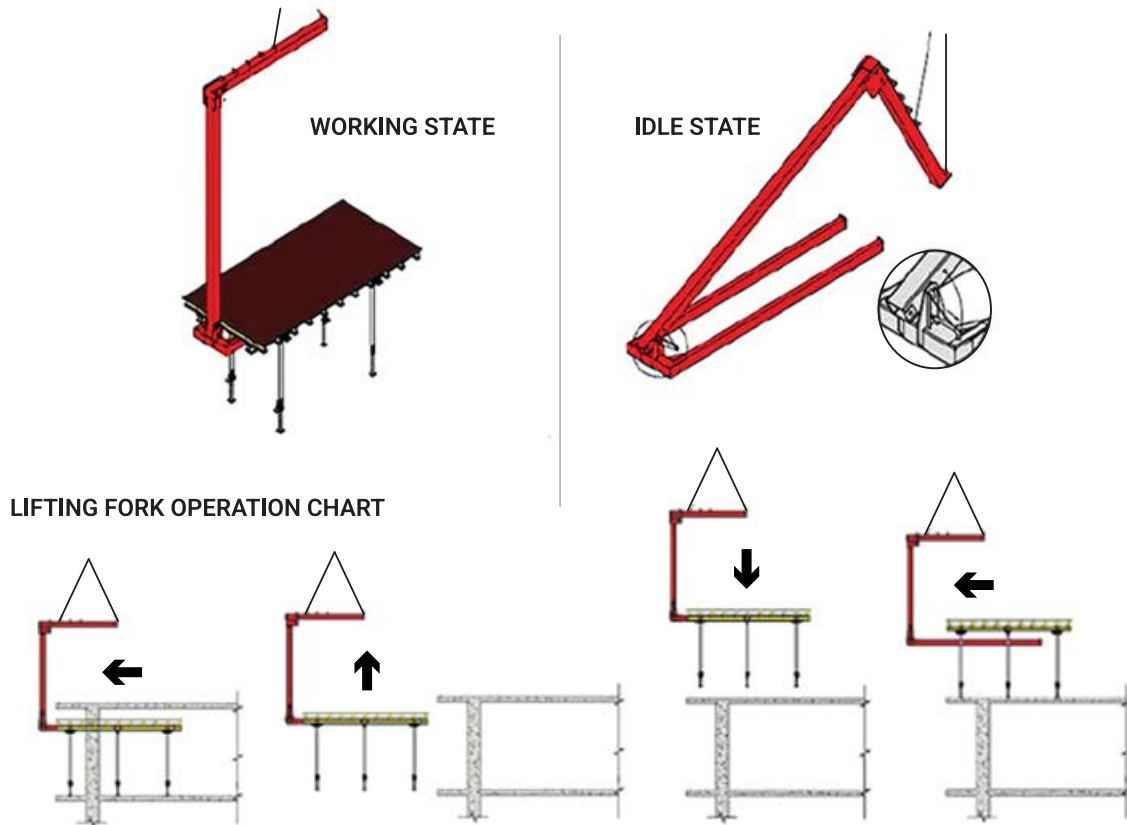

### TABLE HEAD

#### TECHNICAL SPECIFICATIONS:

• Beam Height (mm)	=	150 - 200
• Width (mm)	=	196
• Length (mm)	=	250
• Finished	=	Avail in Painted & Gi

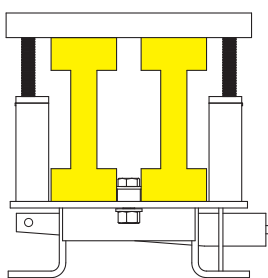

H20 Beam Application

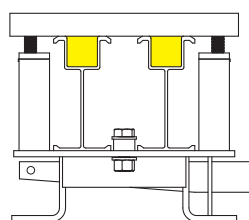

S150 Aluminium Beam

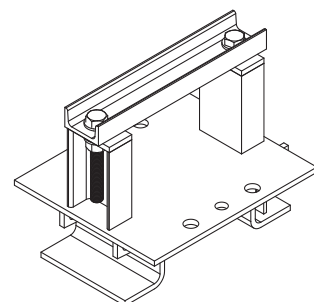

## CREATIVE FORMWORK

### STANDARD COMPENENTS

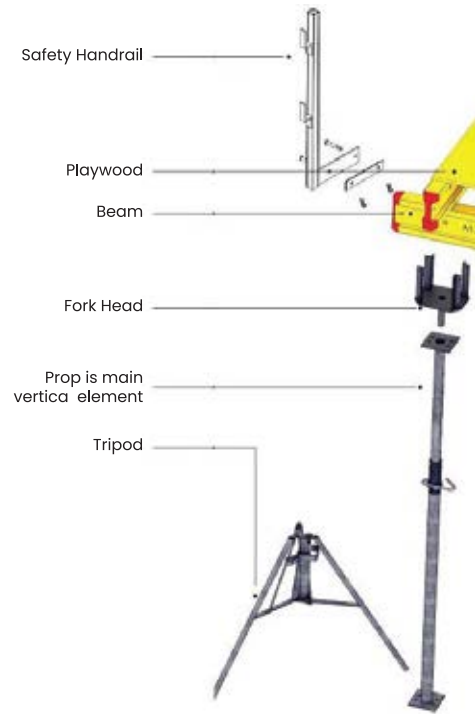
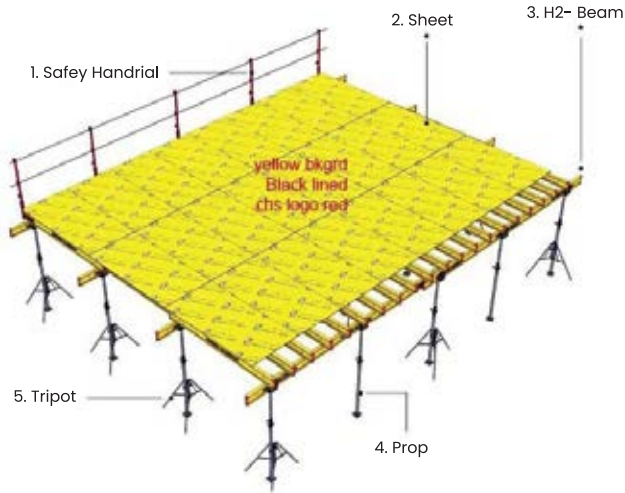

### C-FORK

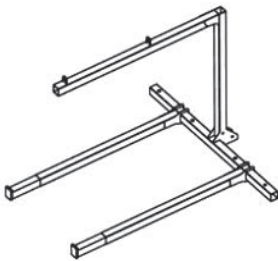

DESCRIPTION	WEIGHT KG
Lefting Element	770

### TABLE HEAD

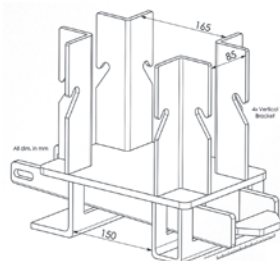

DESCRIPTION	WEIGHT KG
Table Head	15.50

### TABLE TROLLY

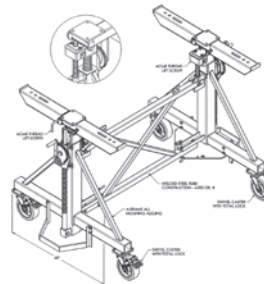

DESCRIPTION	WEIGHT KG
Table Trolley	524

### HANDRAIL SAFETY POST



### TABLE FORMWORK GUARDRAIL

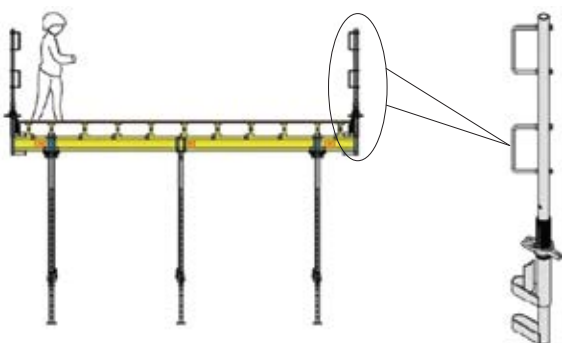

### FABRICATED TABLE



## CREATIVE FORMWORK ACCESSORIES

### PLASTIC CONE (Tie Cone)

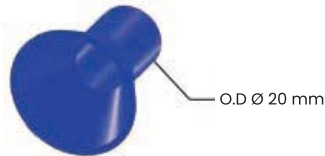

The expandable PVC tube allows the tie bars to be removed after concrete has been placed.

The Cone gives a cover of 10mm to the PVC tubular sleeve / spacer.

### WATER STOPPER

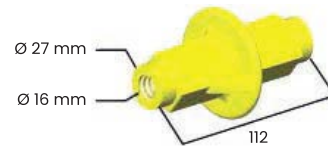

This metal piece is placed in the center of the wall & connected on both sides of the Tie Rods. Its function is to provide a barrier to prevent the penetration of liquids to the inside of the wall.

### COUNTER PLATE (Anchor Plate/Tie Plate)

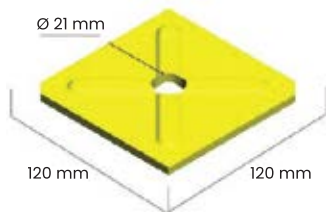

Used with wing nut & tie rod to clamp wall or column shutters together.

Used with wing nut & universal angle tie for fixation of 4 sides of panels of column.

### WING NUT (M16mm)

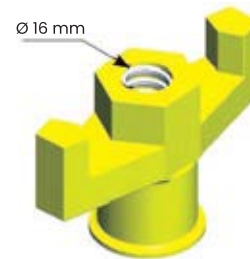

Used with counter plate & tie rod to clamp wall or column shutters together.

Used with counter plate & universal angle tie for fixation of 4 sides of the panels of column with right angle 90°.

### M-TIE RODS



Used to fix complementary formwork during the pouring operation.

Produced in standard length of 6 mtrs. & cut to necessary length on the construction site.

Safe working load : 65 KN  
Diameter : 16 mm  
Length : Tie Rod

We can supply any other length, not maintained in the table, but less than 6m.

### PLASTIC SLEEVE



The expandable PVC tube allows the tie bars to be removed after concrete has been replaced.

## CAT – CLASS 3 LIGHT WEIGHT ALUMINUM MOBILE TOWER

- | Ladder Frames
- | Colour Coded Braces
- | Toe Board Set
- | Class 3 Loading
- | Easy Erection
- | Platform Fitted with Windlock

### | Sizes Available

- A. 1.45 x 2.5 mtr.
- B. 1.45 x 1.8 mtr.
- C. 0.80 x 1.8 mtr.



### | Safe Working Loads

#### Individual Platforms

The maximum safe working loads per individual platform are 294 kg. Uniformly distributed

#### Working Levels

The maximum safe working loads per working level are 588kg.  
On Double Width Towers 294kg.  
On Single Width, a working level is created by use of 2 platforms DW. 1 Platform SW.  
The maximum number of working level per tower is 2.

#### Complete Tower Structure

The maximum safe working load of the Tower structure including self weight & ballast is 1000 kgs.

Kitemark License : KM 25447  
Pasma Member : BSEN IS09001: 1994  
Certificate No. : GS 24730

TOWER REF.	DW-1.80V/2.5V-11.30		DW-1.80V/2.5V-11.80		DW-1.80V/2.5V-12.30	
Working Height	13.3m		13.8m		14.3m	
Tower Height	12.3m		12.8m		13.3m	
Platform Height	11.3m		11.8m		12.3m	
Width	1.45m		1.45m		1.45m	
<b>Length</b>	1.8m	2.5m	1.8m	2.5m	1.8m	2.5m
<b>Weight (kg)</b>	294kg	314kg	300kg	321kg	308kg	329kg

#### DOUBLE WIDTH TOWER 1.45 X 2.5 meter x Height (with Built in Ladder)

S. No.	ITEM DESCRIPTION	Tower Height 3.2	Tower Height 4.2	Tower Height 5.2	Tower Height 6.2	Tower Height 7.2	Tower Height 8.2	Tower Height 9.2	Tower Height 10.2	Tower Height 11.2	Tower Height 12.2	Tower Height 13.2	Tower Height 14.2	Tower Height 15.2	Tower Height 16.2
1	Adj. Leg + Wheel 200 mm	4	4	4	4	4	4	4	4	4	4	4	4	4	4
2	4R Ladder Frame 1.45 x 2.0 m	1	2	2	3	3	4	4	5	5	6	6	7	7	8
3	4R Frame 1.45 x 2.0 m	1	2	2	3	3	4	4	5	5	6	6	7	7	8
4	3R Ladder Frame 1.45 x 1.5 m	-	-	-	-	-	-	-	-	-	-	-	-	-	-
5	3R Frame 1.45 x 1.5 m	-	-	-	-	-	-	-	-	-	-	-	-	-	-
6	2 R Frame / Guardrail 1.0 m	1	-	1	-	1	-	1	-	1	-	1	-	1	-
7	2 R Ladder Frame 1.0 m	1	-	1	-	1	-	1	-	1	-	1	-	1	-
8	Plain Platform 2.5 m	1	1	1	1	1	1	1	1	1	1	1	1	1	1
9	Trapdoor Platform 2.5 m	1	1	1	1	1	1	1	1	1	1	1	1	1	1
10	Horizontal Brace 2.5 m	6	6	6	6	6	6	6	6	6	6	6	6	6	6
11	Diagonal Brace 2.7 m	3	5	7	9	11	13	15	17	19	21	23	25	7	29
12	Stabilizer 7 (Small)	-	-	4	4	4	-	-	-	-	-	-	-	-	-
13	Stabilizer 10 (Medium)	-	-	-	-	-	4	4	4	4	4	-	-	-	-
14	Stabilizer 15 (Large)	-	-	-	-	-	-	-	-	-	-	4	4	4	4
15	Toe Board Set 1.45 x 2.5 m	1	1	1	1	1	1	1	1	1	1	1	1	1	1

## HEAVY DUTY STEEL MOBILE TOWER

### STAIRCASE ACCESS TOWER

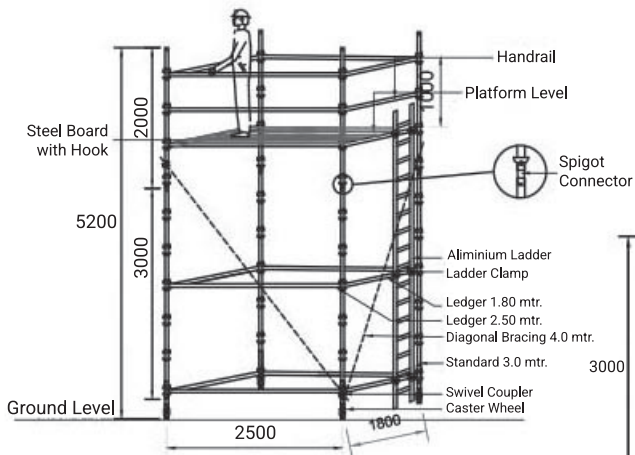
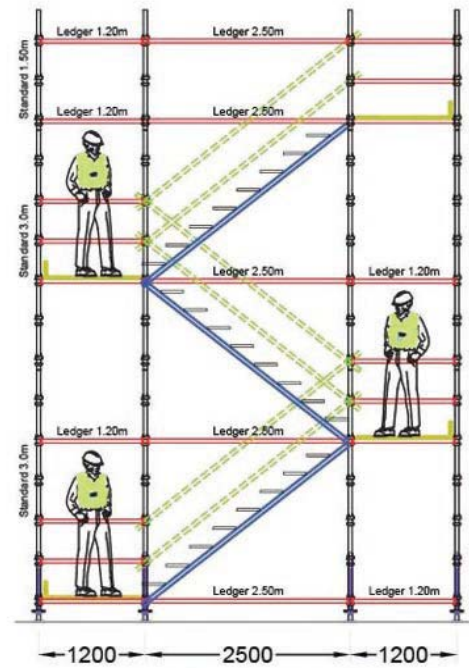
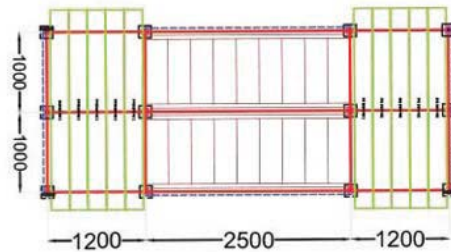

Mobile Tower with CL - System



Standard 3.0 mtr.

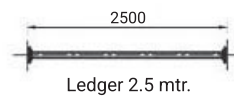

Ledger 2.5 mtr.

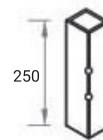

Spigot Connector



Adjustable Base Jack 760 mm

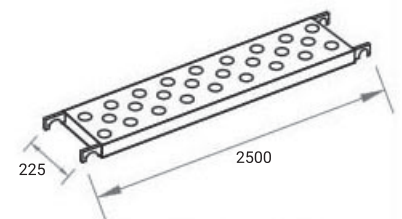

Steel Board with Hook 2.5 mtr.

# SCAFFOLD CASTORS

## Scaffold Castors S.W.L. Upto 820 Kgs.

RDS/Scaff series are with wheel lock and swivel seal & are provided with either socket or spring/loaded solid plugs. Load capacity in addition to the Dynamic loads SAFE working SWL static loads are also shown in the table.

### DATA FOR SCAFFOLDING TYPE TOP FIXTURE

Wheel Dia <b>A</b>	Tread Width <b>B</b>	Overall Height <b>C</b>	Offset <b>D</b>	Wheel Type	SOCKET & SPRING LOADED SOLID PLUG FITTING					
					Dynamic Capacity	Static Capacity S.W.L	Catalog Reference	Static Capacity S.W.L	Catalog Reference	
					in Kgs.	in Kgs.		in Kgs.		
150 (6")	44.5 (1 3/4")	197 (7 3/4")	44.5 (1 3/4")	Rubber Tyred (RT)	370	820	RD5 / SCF 2/ RT /150 RD5 / SCF 2/C /150 RD5/ / 2/N/150 RD5/ SCF2/P/150	820	RD5/SPS 1/RT/150 RD5/SPS 1/C/ 150 RD5/SPS 1/ N/150 RD5/SPS 1/P/150	
	50 (2")			Cast Iron (C)	410					
	Nylon (N)			410						
	Phenorex (P)			410						
200 (6")	50 (2")	243 (9 9/16")	44.5 (1 3/4")	Rubber Tyred (RT)	500	820	RD5/ SCF 2/RT /200 RD5 / SCF 2/C /200 RD5 / SCF 2 / N/200 RD5 / SCF 2/ P/ 200	820	RD5/ / SPS RT/200 RD5/ / SPS 1/ C/200 RD5/ SPS 1/ N/200 RD5/ SPS 1/P/200	
				Cast Iron (C)						
				Nylon (N)						
				Phenorex (P)						

Roller & Ball Bearing also available at an extra cost. > Finish-Bright zinc Galvanized.

**NOTE:** Tolerance on the wheel diameter 'D' upto & including 100 mm shall be ± 2 mm & for the diameters greater than 100 mm be ± 2%.

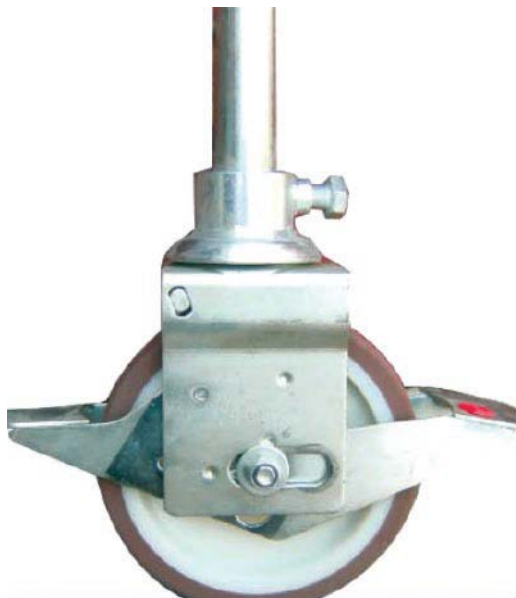

Revvo / UK



Rexello

# CHS

Creative House Scaffolding LLC

Sale . Hire . Contracts

## CREATIVE POWER TOWERS



*Organization Instilled with  
Passion & Dedication!*

## CREATIVE POWER TOWERS

### SIX LIFT (Access Division)

#### SPECIFICATIONS

SIZE		METRIC	BRITISH
Max. Working Height (Indoor)	<b>A</b>	5.90m	19ft 4in
Max. Working Height (Outdoor)		5.90m	19ft 4in
Max. Platform Height (Indoor)	<b>B</b>	3.90m	12ft 10in
Max. Platform Height (Outdoor)		3.90m	12ft 10in
Overall Length	<b>C</b>	1.44m	4ft 9in
Overall Width	<b>D</b>	0.76m	2ft 6in
Overall Height (Rails Up)	<b>E</b>	1.92m	6ft 4in
Overall Height (Rails Down)	<b>F</b>	1.52m	5ft
Platform Size (Length×Width)		1.29m×0.70m	4ft 3in×2ft 4in
Ground Clearance		0.06m	2in
Wheelbase	<b>H</b>	1.14m	3ft 9in
Tyres		φ150×50mm	φ 6×2in

PERFORMANCE		METRIC	BRITISH
S.W.L		240 Kg.	529lb
Max. Occupants (Inside/Outside)		1/0	1/0
Max. Working Slope		X-1°/Y-1°	X-1°/Y-1°
Up/Down Speed		38/25 Sec	38/25 Sec

WEIGHT		METRIC	BRITISH
Overall Weight		530 kg.	1168 lb

POWER		METRIC	BRITISH
Hydraulic Tank		3L	0.8gal
Battery		12V/85Ah	12V/85Ah
Charger		12V/15A	12V/15A
Lifting Motor		12VDC/0.8kW	12VDC/0.8kW

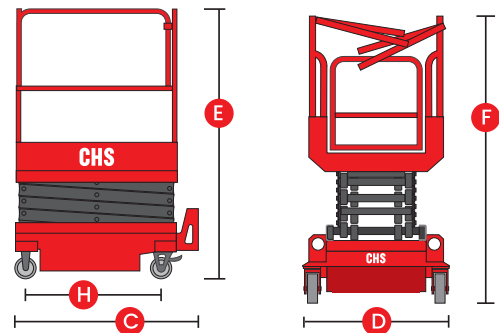
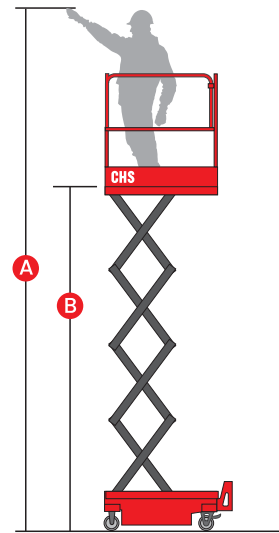

#### FEATURES

##### Standard Items

- Self-Locking Gates
- Automatic Braking System
- Emergency Descent System
- Tubing Explosion-Proof System
- Onboard Fault Diagnostic System
- Tilt Alarm
- Motion Alarm
- Horn
- Hour Meter
- Safety Arm For Troubleshooting
- Standard Transport Forklift Holes
- Charging Protection System
- Flashing LED Beacon
- Charging Indicator
- Lanyard Attachment Point
- Tie-Down And Lifting Points
- Platform Load Sense System
- Emergency Stop Button

## CREATIVE POWER TOWERS

### SEVEN LIFT (Access Division)

#### SPECIFICATIONS

SIZE		METRIC	BRITISH
Max. Working Height	<b>A</b>	6.50 m	21 ft 4 in
Max. Platform Height	<b>B</b>	4.50 m	14 ft 9 in
Overall Length	<b>C</b>	1.58 m	5 ft 2 in
Overall Width	<b>D</b>	0.76 m	2 ft 6 in
Overall Height (Rails Up)	<b>E</b>	2.05 m	6 ft 9 in
Overall Height (Rails Down)	<b>F</b>	1.68 m	5 ft 6 in
Platform Size (Length×Width)		1.44 x 0.74 m	4 ft 9in x 2ft 5 in
Platform Extension Size	<b>G</b>	0.60 m	2 ft
Ground Clearance (Stowed/Raised)		0.07 m/0.016m	3 in / 1 in
Wheelbase	<b>H</b>	1.12 m	3ft 8 in
Turning Radius (Inside/Outside)		0m/1.30 m	0m / 4ft 3in
Tyres		Ø305 x 100 mm	Ø305 x 100 mm

PERFORMANCE		METRIC	BRITISH
S.W.L		230 kg.	507 lb
S.W.L on Extension		113 kg.	249 lb
Max. Occupants (Indoor/Outdoor)		2/1	2/1
Gradeability		25%	25%
Travel Speed (Stowed)		4.5km/h	2.80 mph
Travel Speed (Raised)		0.6km/h	0.37 mph
Max. Working Slope		X-1.5°/Y-3°	X-1.5°/Y-3°
Up/Down Speed		22/20 Sec.	22/20 Sec.

WEIGHT		METRIC	BRITISH
Overall Weight		1200 kg.	2646 lb

POWER		METRIC	BRITISH
Hydraulic Tank		3.5L	0.9 gal
Battery		24V/115 Ah	24V/115 Ah
Charger		24V/15 A	24V/15 A
Driving Motor		2×24VDC/0.5 kW	2×24VDC/0.5 kW
Lifting Motor		24VDC/2.2 kW	24VDC/2.2 kW

#### FEATURES

##### Standard Items

- Proportional Joystick Controls
- Self-lock Gates
- One-Way Platform Extension Deck
- Drivable at Full Height
- Drive Enable
- Non-Marking Tires
- Automatic Brake System
- Emergency Descent System
- Tubing Explosion-Proof System
- Onboard Fault Diagnostic System
- Horn
- Tilt Alarm
- Motion Alarm
- Hour Meter
- Two-Wheel Drive
- Two-Wheel Steering
- Automatic Pothole Protection
- Safety Arm for Troubleshooting
- Standard Transport Forklift Holes
- Charging Protection System
- Flashing LED Beacon
- Foldable Guard Rails
- Charging Indicator
- Manual Brake Release
- Emergency Stop Button
- Tie-Down & Lifting Points
- Lanyard Attachment Point
- Platform Load Sense System

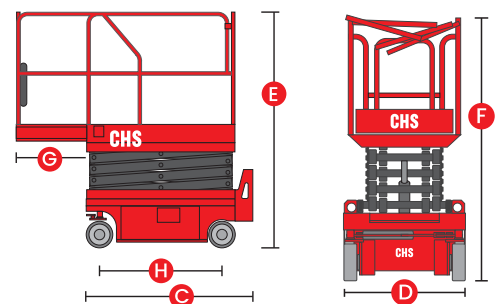
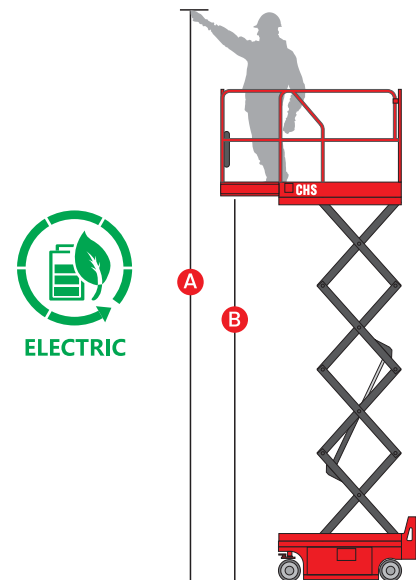

## CREATIVE POWER TOWERS

### SPECIFICATIONS

DIMENSION		METRIC	BRITISH
Max. Working Height	<b>A</b>	7.80m	25ft 7in
Max. Platform Height	<b>B</b>	5.80m	19ft
Overall Length	<b>C</b>	1.86m	6ft 1in
Overall Width	<b>D</b>	0.76m	2ft 6in
Overall Height (Rails Up)	<b>E</b>	2.15m	7ft 1in
Overall Height (Rails Down)	<b>F</b>	1.83m	6ft
Platform Size (Length x Width)		1.67m x 0.74m	5ft 6in x 2ft 5in
Platform Extension Size	<b>G</b>	0.90m	2ft 11in
Ground Clearance (Stowed/Raised)		0.09m/0.016m	3in/1in
Wheelbase	<b>H</b>	1.36m	4ft 5in
Turning Radius(Inside/Outside)		0m/1.64m	0in/5ft 5in
Tyres		φ323x100mm	φ323x100mm

PERFORMANCE		METRIC	BRITISH
S.W.L		250kg	551lb
S.W.L on Extension		113kg	249lb
Max. Occupants (Indoor/Outdoor)		2/1	2/1
Gradeability		25%	25%
Travel Speed(Stowed)		5.5km/h	3.41mph
Travel Speed(Raised)		0.6km/h	0.37mph
Max. Working Slope		X-1.5°/Y-3°	X-1.5°/Y-3°
Up/Down Speed		22/22sec	22/22sec

WEIGHT		METRIC	BRITISH
Overall Weight		1630kg	3594lb

POWER		METRIC	BRITISH
Hydraulic Tank		7L	1.7gal
Lithium Battery		28.8V/125Ah	28.8V/125Ah
Charger		28V/30A	28V/30A
Driving Motor		2x15VAC/0.5kW	2x15VAC/0.5kW
Lifting Motor		15VAC/3kW	15VAC/3kW

### FEATURES

#### Standard Items

- Proportional Joystick Controls
- Self-lock Gate on Platform
- Drivable at Full Height
- Non-Marking Tyres
- Two-Wheel Drive
- Two-Wheel Steering
- Automatic Brake System
- Charging Protection System
- Emergency Descent System
- Onboard Diagnostic System
- Automatic Pothole Protection
- Horn
- Tilt Alarm
- Hour Meter
- Drive Enable
- All Motion Alarm
- Charging Indicator
- Flashing LED Beacon
- Foldable Guard Rails
- Hydraulic Oil Receiver
- Cylinder Holding Valve
- Emergency Stop Button
- Manual Brake Release
- Tie-Down & Lifting Points
- Lanyard Attachment Point
- Platform Load Sense System
- Pure Electric Steering System
- Safety Arm for Troubleshooting
- Kinetic Energy Recovery System
- Standard Transport Forklift Holes
- One-Way Platform Extension Deck

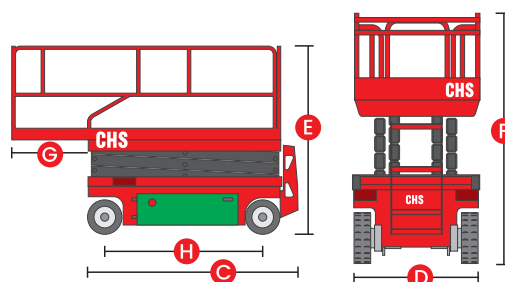
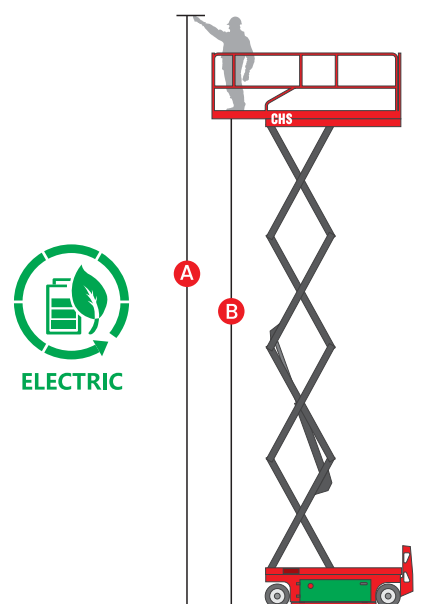

## CREATIVE POWER TOWERS

### POWER TOWER DUO (2 Person)

#### SPECIFICATIONS

##### WORKING DIMENSIONS

Max Working Height	: 5.10 m
Max Platform Height	: 3.10 m
Basket Dimensions	: 1.52 x 0.75 m
Working Footprints	: 1.79 x 1.22m
Safe Working Load	: 250 kg
Max Manual force	: 400N (2 persons)

##### POWER

Battery	: 12V c/w automatic charger.
Mains	: 110V or 230V.
Controls	: Simple push button basket controls.

Construction : Heavy duty fabricated steel superstructure, stainless steel bushed pivots, tough powder coated finish.

Safety : CE marked, complies fully with EN280 & relevant European machinery directives. Full fail-safe hydraulics, automatic locking wheels.

Options : Tilt alarm c/w auto cut-out. Pipe Carrying kit (max 2" pipe). Tool tray. Foam buffer kit.



#### FEATURES

- Easy access gate
- Large 1.52 x 0.75 m platform size
- Only 0.78 x 1.6 m working footprint
- 3.1m platform height
- 5.1m working height
- 2 person capacity
- Patented stabiliser deployment on elevation
- 250kg safe working load (2 Persons plus tools)
- Compact - only 0.78m wide, passes easily through standard doorways
- Stabilisers interlocked preventing elevation until stabilisers deployed correctly

#### NANO PUSH



##### WORKING DIMENSIONS

Max Working Height	: 4.50m
Max Platform Height	: 2.50m
Basket Dimensions	: 1m x 0.73m
Working Footprints	: 1.19m x 0.75m
Safe Working Load	: 200kg
Max Manual Force	: 200N

#### PECO LIFT



##### WORKING DIMENSIONS

Max. Working Height	: 3.50m
Max Platform Height	: 1.50m
Basket Dimensions	: 720mm(L) x 600 mm (W)
Working Footprints	: 985 mm x 700 mm
Safe Working Load	: 150 kg
Max Manual force	: 200 N

#### ECO LIFT



##### WORKING DIMENSIONS

Max Working Height	: 4.20m
Max Platform Height	: 2.20m
Basket Dimensions	: 800 mm(L) x 600 mm(W)
Working Footprints	: 1.3m x 0.7m
Safe Working Load	: 150 kg
Max Manual Force	: 200 N

# SCAFFOLD PIPES

Scaffold Pipe available in Galvanized/Black Version

Technical Data for Scaffold Pipe as per specification BS EN 39:2001

Outside Diameter		Thickness		Weight per unit length	
Inches	mm	Inches	mm	Ibs/foot	kg/m
1.1/2	48.3	0.126	3.2	2.392	3.56
1.1/2	48.3	0.157	4.0	2.937	4.25

## CHEMICAL COMPOSITION

%C Max	%Si Max	%Mn Max	%P Max	%S Max	%Al Max
0.2	0.05	1.4	0.04	0.045	0.02

## MECHANICAL PROPERTIES

Yield Strength	: 235 MPa (min.)
Tenile Strength	: 340-520 Mpa
Elongation	: 24% (min.) on Guage Length, 5.65 x Sq. Root of Cross Sectional Area
End Finish	: Plain End
Straightness	: 1 mm in 500 mm length
Zinc Coating	: 40 Microns Minimum Outside
Marketing	: EN 39 - Date - Thickness at every 1 meter Length (Upon request)
Delivery Condition	: As rolled condition (without protection) Hot dipped Galvanized



## SCAFFOLD

**WOODEN & STEEL BOARDS****| BS2482 SCAFFOLD WOODEN BOARD**

Our Scaffold is fully complying with the standard issued by the British Standard institute & are monitored for quality under the ISO 9001 accreditation. All BS2482: 1981 scaffold boards are marketed with the following information, which is embossed on the end band.

The word "support every 1.5m or 1.2m max" it is used as a temporary access platform. Standard Size: 38mm x 225mm x 3.9m long. Shorter lengths also available depend on the quantity.

**| SCAFFOLD LAMINATED BOARDS**

Laminated Board is manufactured from LVL (Laminated Veneer Lumber). The structural uniformity of LVL makes it the perfect solution for a safe, lightweight scaffold board. Each Board is made from many layers of thin veneer, which increases the reliability & strength of the product.

Size : 38 mm x 225 mm x Length

Unit Weight : 4.75kg/m

Every board is individually proof tested to verify that it conforms to OSHA deflection limits before being branded as a scaffold board. Shorter lengths also available depend on the quantity.

**| SCAFFOLD METAL BOARD****BS EN 12811-1**

Scaffold metal deck is now used as a replacement of timber boards as a temporary access platform it boasts high load carrying capacity & triples the life span of a timber board for a competitive price.

it is available in painted & galvanized version and a 4m boards weight 18kgs. for a 38mm height boards. It comes in various sizes from 1m to 4m length. All steel boards comply to BS EN 12811-1 & gone through stringent technical test as well many international third part recognition. It is recommended to use BRC to secure the steel board. Customer name can be embossed at both caps, depending on the quantity.

Size : 38 mm x 225 mm x Length

Unit Weight : 4.50kg/m tr

# LADDER & UNIT BEAMS

## LADDER BEAMS

Ladder Beam are made of standard 48.3 Tube CHS ladder beam are made to high standards BS1139 / EN 39 which Notched ends to the rungs to maintain maximum strength at the joints.

Description	Weight 4mm	Weight 3.2mm
3 mtr Ladder Beam	40	32
4 mtr Ladder Beam	53	43
5mtr Ladder Beam	66	54
6 mtr Ladder Beam	81	65
7 mtr Ladder Beam	93.4	75

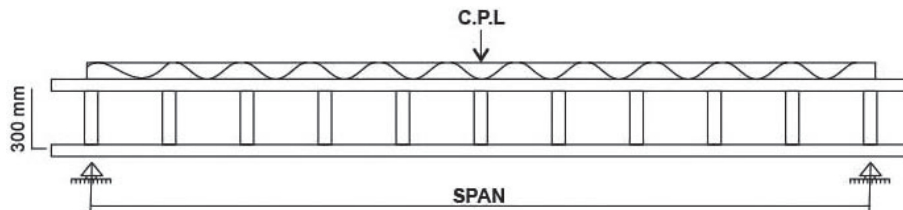

## UNIT BEAM STEEL

Can be used either to provide a clean span between scaffold or may be assembled as prefabricated framework for temporary building or other structure. Complete spans can be quickly erected utilizing individuals beam lengths. Beam ends are self locating to provide fast on side assembly & are secured using Mx20x50 bolt, complete with nut and washer.

Top & bottom chords manufactured from 48.30/Dx4mm thick steel tube to BS 1139, cut to length 2.44m or 3.6m at 610mm centre vertically. Heavy duty spigot welded in one end to chords. End post is 48.3mm O/Dx3.2mm thick to BS 4360

Type (Length ft)	Length (Meter)	Plate Type	Plate Hole Dimension (mm)	Weight
12	3.66	2 holes	022x51c/c x	38.6
8'	2.44	2 holes	483 vertical centers	52.4

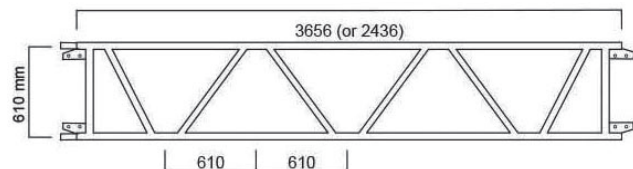

Diagonal brace tubes are 27mm O/D x 3.2mm thick steel tube grade 13C BS 4380. Coupler Plate with 2 or 3 holes are welded on top & bottom at bottom ends. Supplied complete with bolts & nuts.

**Finishing:** Painted or Galvanized.

## UNIT BEAM ALUMINIUM

### Available Sizes:

- > 4.1 meter
- > 6.1 meter
- > 8.1 meter

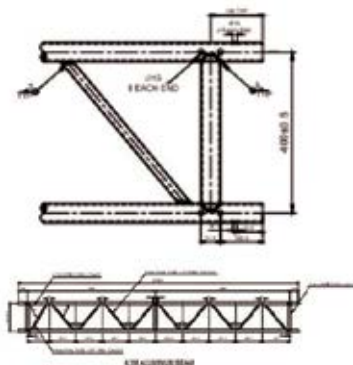

## SCAFFOLD FITTINGS



**Drop Forged Swivel Coupler**  
Size: 48.3mm  
(EN-74A), Used for the connection of 2 tube at any-angles.



**Double Coupler**  
Size: 48.3mm  
(EN-74B), Used to join 2 scaffold tubes at a right angle (90°).



**Putlog Coupler**  
Size: 48.3 mm  
Used for the connection of putlog & transom to ledgers.



**Board Retaining Coupler**  
Size: 48.3 mm  
(EN-74) Boards are quickly locked in the correct position, providing high resistance to both lateral & upward movement.



**Girder Coupler Fixed**  
Size: 48.3 mm  
(EN-74) Provides a fixed 90° coupling of a scaffold girder. Must be used in pairs.



**Sleeve Coupler**  
Size: 48.3mm  
(EN-74) Used as the external connection of 2 tubes end-to-end provides a more secure joint than the Joint Pin.



**Fix Girder Coupler & Swivel Girder**  
Size: 48.3 mm  
(EN-74) Provides a rotating coupling of a scaffold tube to an I' beam girder. Must be used in pairs.



**Inner Joint Pin**  
Size: 48.3mm  
For vertical & Handrail application.



**Supa Tie Coupler Right**



**Supa Tie Coupler Left**



**Ladder Clamp**  
Size: 48.3mm



**Toe Board Clamp**  
Size: 48.3mm

## SCAFFOLD FITTINGS



Fencing Coupler  
Size: 48.3mm



Band & Plate



Prop Swivel Coupler



Prop Double Coupler



Fixed Finial



Swivel Finial



T-Bolt



Unifix



Steel Pallet



Pallet Cup

## SCAFFOLDING SUPA-TIE

The Supa Tie is used to secure a scaffold structure; it is an essential tie for scaffolding.

### BENEFITS / FEATURES:

- > The Scaffold Supa Tie is a safe & versatile scaffold tie that can be used in many scenarios.
- > The tie is hard & very durable, allowing it to be used many times over
- > This product is to be used in conjunction with our M16 drop-in anchor.

Single Shear (kN)	Tension (kN)	
60.3	90.4	M16 Gd 8.8

**NOTE:** This value apply to the bolt only. Other failure modes will occur before the bolt fails, such as coupler slip & anchor failure in the supporting material.



Uni-Fix



Supa Tie

## SCAFFOLD TOOLS / ANCILLARY



### Tube End Cap

To protect the users from injuries against scaffold protruding pipe-ends. Simple to fix & compliance to safety requirement.  
High visible color and it fits any type of scaffold tubes of 48.3 mm diameter.

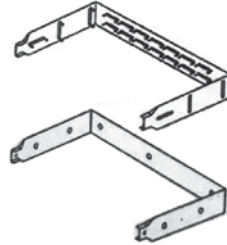

### Board End Bands

Size : 550 x 25 x 0.5 mm  
Made of mild steel & comply to BS 729 Standards.



### Gin Wheel Pulley

Used to assist the loading of supplies & equipment onto scaffolding.



### Ratchet Spanner

Scaffold RATCHET 17/21 is made especially for use on BS/EN scaffold couplers.

It is made from high quality Chrome Vanadium Steel & heat treated for durable & longer life span.



### Spirit Level

Scaffold bridge level (Magnetic) made of aluminum especially designed to be used with all types of scaffold for easy & accurate level reading.



### Scaffold Box Spanner

Scaffold spanner 7/16", is made especially for use on BS/EN scaffold couplers.

It is made from high quality Chrome Vanadium Steel & heat treated for double & longer life span.



### T-Bolt with nut & Washer (Zinc Plated)

Drap forged couplers accessory



### Scaffold Clamp Lifting Bag

Coupler lifting bag available in 50 kg & 30kg.  
Also available in leather



### Scaffold Tag & Holder

To indicate the safety level for scaffolding during erection, after completion & also during dismantling.

## SCAFFOLD TOOLS / ANCILLARY



Measurement Tape  
5m Long



Fall Arrest



Podger Hammer &  
Safety Lanyard



### Scaffold Safety Harness / Energy Absorber

A shock absorber is to be used with our harnesses (on the door sell fastening/D-Ring only). In case of a fall, it will absorb 1 part of the shock (which would not be the case with a rope). The shock resistance in case of a fall for the system will be less than 600 kg (as per the requirement of EN 355) CE Approved & confirmed European norm EN 361.



### Leather Belt

Comes complete with  
> Spanner holder, > Ratchet holder, > Spirit Level holder, > Measuring Tape holder



# SCAFFOLD SUB CONTRACT JOBS

**CHS** is renowned for maintaining its international standard in the scaffolding industry. It caters to clients of the civil construction, Industrial sites in the UAE. **CHS** undertake complete range of contract jobs. **CHS** has expertise in some of the typical scaffolding application, Such as Industrial Scaffold, OHTL Works, Stage & Events, Access Scaffolds, & Bird Cage Scaffolds for interior work application Outdoor Advertising Scaffold, Ship repairs, Slab & Column formwork. **CHS** has registered a steady growth due to the dynamic management led by its highly experienced & qualified professionals.

**CHS** our world is scaffolding, it's our commitment to design, supply & deliver the highest quality scaffoldings to our customers on competitively & on time. It had earned a very deserving ISO 9001:2015 Certificate

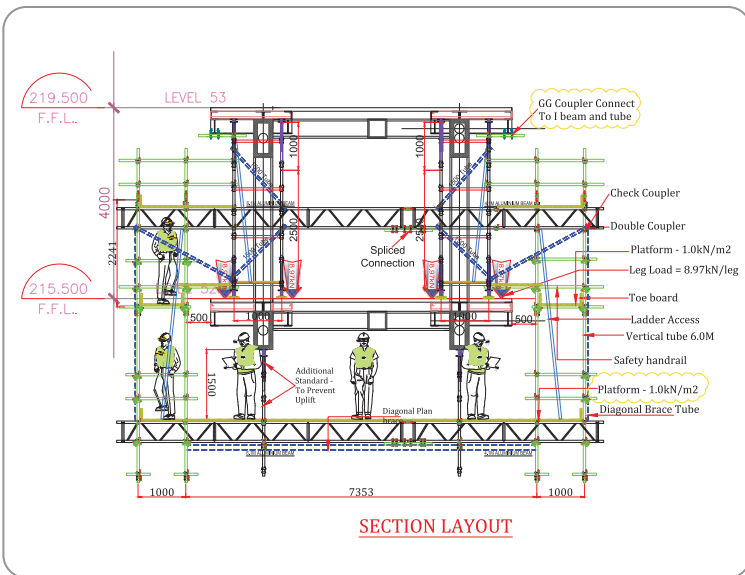

**CHS Creative House Scaffolding LLC**  
Sole - Hire - Contracts  
www.chsdx.com

DUBAI  
Tel: (9714-4474117) Fax: (+97144474116), P.O. Box 115713  
Email: design-dept@chsdx.com

PROJECT: SKYWALK HANGING SCAFFOLD	LOCATION: DUBAI - UAE	ENQ. NO : 830/D-IA
CLIENT: SHENYANG YUANDA ALUMINIUM INDUSTRY ENGINEERING CO.		SHEET. NO. - / REV.
		MS0860/ 29-08 / RD

METHOD STATEMENT	PREPARED BY: MAHMAD HUSEN	DATE: 29/08/2018	CHECKED BY: JAMEEL AHMED	DATE: 29/08/2018
------------------	---------------------------	------------------	--------------------------	------------------

**METHOD STATEMENT FOR THE ERECTION AND DISMANTLING OF LEVEL 52 SKYWALK BRIDGE HANGING SCAFFOLD**

**TABLE OF CONTENTS**

01.0 Introduction	2
02.0 Scope of work	2
03.0 Responsibility	2
04.0 Description of Work	2
04.1 method of erection	3
04.2 method of dismantle	4
05.0 Labour and material arrangement	04
06.0 Supervision Arrangements	06
07.0 Health & Safety Requirements	06
08.0 Environmental Requirments	07
09.0 Logistic Arrangements	08
10.0 Security Arrangements	08
11.0 Quality Arrangements	09
12.0 Attachment	09

ACTIVITY		ERECTION AND DISMANTLING OF HANGING SCAFFOLD				CONTROLLED BY WHOM	RESIDUAL RISK
S. N.	ACTIVITY	HAZARD	HARM	RISK (L X S)	CONTROL MEASURES		
03.	Scaffold erection	Full or partial collapse of scaffold during erection and dismantle	Death, major injuries, minor injuries.	3 X 5	<ul style="list-style-type: none"> <li>Scaffold to be erected in accordance with BS EN 12811 and requires a design drawing to be produced.</li> <li>The scaffold will be erected / dismantled progressively to ensure a section remains guarded for passing or removing material.</li> <li>Before erecting suspension points, tie points and use of support straps or inertia reels there must be approval from the client to verify the strength of imposed loads.</li> <li>Where structural members are of insufficient capacity to withstand the forces imposed on them by a drop scaffold or where there is not a structure suitable as an overhead support, a temporary structure maybe erected using scaffold tube.</li> <li>This structure acts as a counterweight and requires to be designed to 3 times the likely load imposed on it.</li> <li>No material storage on the scaffold is permitted.</li> <li>All scaffolders employed to undertake this work will be competent and fully trained to SG4 standards.</li> <li>Scaffolders to wear a suitable full body safety harness with twin-tailed lanyards, the harness to be used in accordance with current NASC Guidance Note SG4.</li> <li>The use of support straps (across beam or steel etc.) or inertia reels will be used on commencement of the scaffold erection.</li> <li>Check fittings to be installed on the dropper tubes to aid descent of the scaffold.</li> <li>Trapeze tube to be adequate size for scaffolder to work from and have check fittings attached to prevent slip.</li> <li>During erection and dismantle all scaffolders to be connected to a suitable anchorage point before descending down the drop tubes to commence erecting the scaffold grid.</li> </ul>	Site Supervisor	M
04.	Scaffold erection	Fall of persons during erection and dismantle.	Death, major injuries, minor injuries.	3 X 5	<ul style="list-style-type: none"> <li>The work area is to be barriered off using suitable means to prevent access.</li> <li>Materials to be stored by suitable means to prevent inadvertent movement i.e. scaffold fittings to be bagged.</li> <li>No other materials to be stored on the scaffold during erection or</li> </ul>	Site Supervisor	M
05.	Scaffold erection	Fall of materials during erection and dismantle.	Death, major injuries, minor injuries.	5 X 3	<ul style="list-style-type: none"> <li>The work area is to be barriered off using suitable means to prevent access.</li> <li>Materials to be stored by suitable means to prevent inadvertent movement i.e. scaffold fittings to be bagged.</li> <li>No other materials to be stored on the scaffold during erection or</li> </ul>	Site Supervisor	M

Page 3 of 6

ACTIVITY		ERECTION AND DISMANTLING OF HANGING SCAFFOLD				CONTROLLED BY WHOM	RESIDUAL RISK
S. N.	ACTIVITY	HAZARD	HARM	RISK (L X S)	CONTROL MEASURES		
<p><b>3.2 Design Check for Transoms:</b></p> <p>a. Loads</p> <ul style="list-style-type: none"> <li>Dead Load = 0.30 kPa x 1.20 m = 0.36 kN/m</li> <li>Live Load = 1.50 kPa x 1.20 m = 1.80 kN/m</li> <li>Design Load, w = 2.16 kN/m</li> </ul> <p>b. Reaction at Supports</p> <ul style="list-style-type: none"> <li>Spacing Between Supports = 1.20 m</li> <li>Reaction, R = <math>\frac{2.16 \text{ kN/m} \times 1.20 \text{ m}}{2}</math> = 1.30 m</li> <li>Reaction, R = 1.40 kN</li> </ul> <p>c. Moment at Midspan</p> <ul style="list-style-type: none"> <li>Moment, M = <math>\frac{2.16 \text{ kN/m} \times (1.20 \text{ m})^2}{8}</math> = 0.46 kN-m</li> </ul> <p>d. Remarks:</p> <ul style="list-style-type: none"> <li>Actual moment = 0.46 kN-m</li> <li>Working moment of resistance = 0.92 kN-m</li> <li>Therefore, transoms are safe.</li> </ul> <p><b>3.3 Design Check for Ledgers:</b></p> <p>a. Loads</p> <ul style="list-style-type: none"> <li>Dead Load = 0.30 kPa x 0.65 m = 0.19 kN/m</li> <li>Live Load = 1.50 kPa x 0.65 m = 0.98 kN/m</li> <li>Design Load, w = 1.17 kN/m</li> </ul> <p>b. Reaction at Supports</p> <ul style="list-style-type: none"> <li>Spacing Between Supports = 2.50 m</li> <li>Reaction, R = <math>\frac{1.17 \text{ kN/m} \times 2.50 \text{ m}}{2}</math> = 1.46 kN</li> </ul> <p>c. Moment at Midspan</p> <ul style="list-style-type: none"> <li>Moment, M = <math>\frac{1.17 \text{ kN/m} \times (2.50 \text{ m})^2}{8}</math> = 0.73 kN-m</li> </ul>							



**Creative House Scaffolding LLC**

Sale . Hire . Contracts

# **PRODUCTS GALLERY**

- Column Formwork
- Wall Formwork
- Slab, Cuplock
- Prop Jack & Staircase
- Access Scaffolding

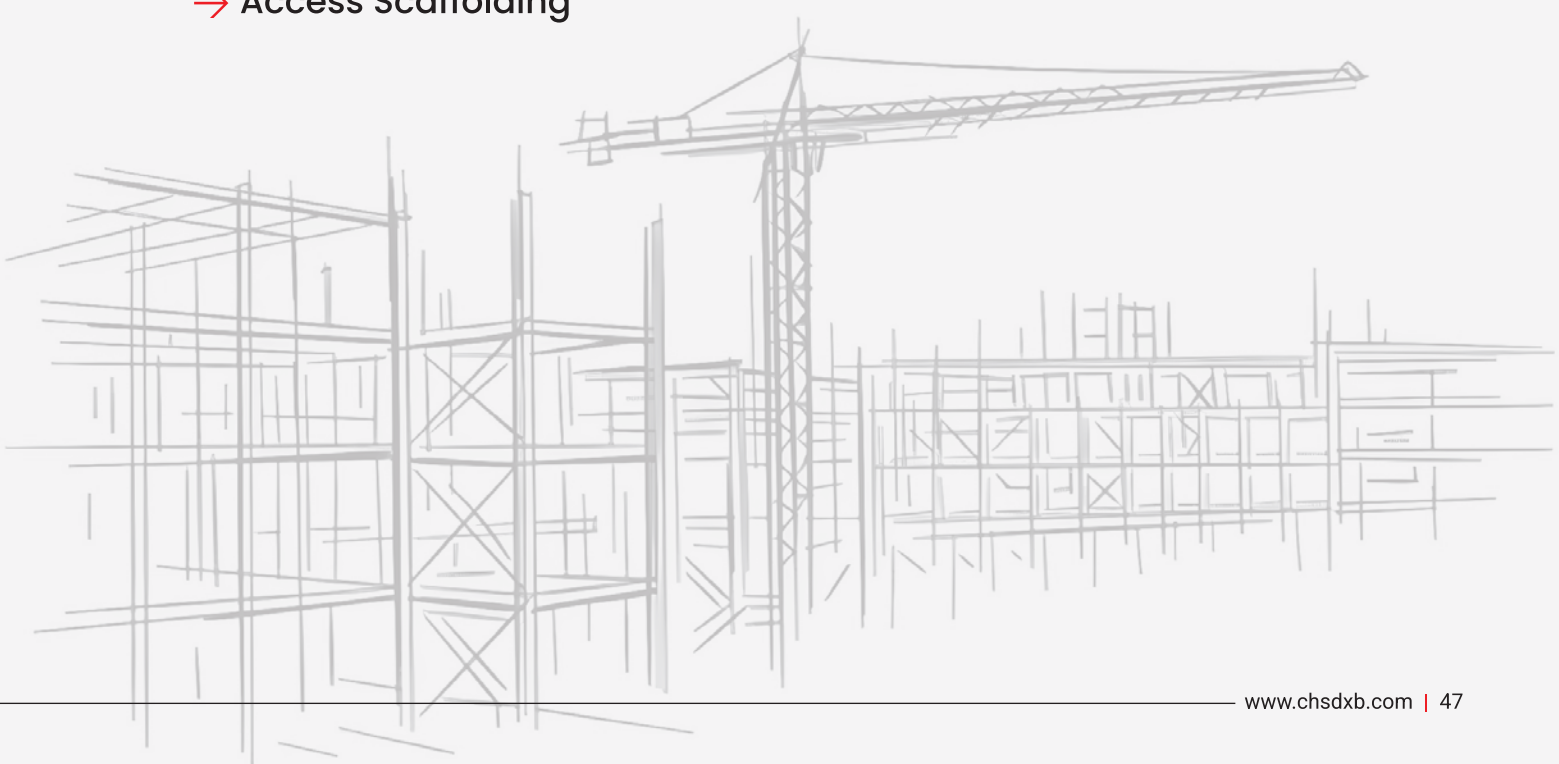

## COLUMN FORMWORK



DRIVEN BY  
**LEADERSHIP,**  
UNITED BY  
**PURPOSE!**



## WALL FORMWORK

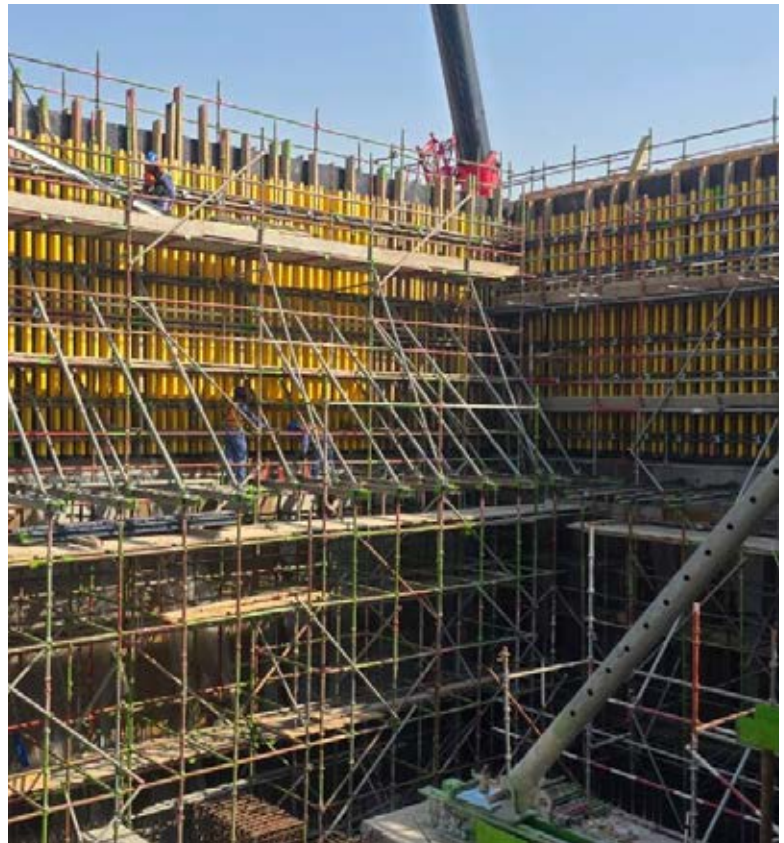

## SLAB FORMWORK



## SLAB FORMWORK & STAIRCASE



## ACCESS SCAFFOLDING



----HEADING MISSING ----????



## OHTL ROAD LINE PROTECTION





## CHS CLIENTS



# CHS<sup>®</sup>

Creative House Scaffolding LLC

Sale . Hire . Contracts

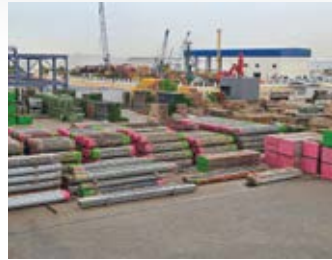

## CREATIVE HOUSE

GROUP OF COMPANIES



DRIVEN BY LEADERSHIP,  
UNITED BY PURPOSE...

CONTRACT | DESIGN | SUPPLY | INSTALLATION

# CHS

Engineered for Performance,  
Designed for Simplicity & Speed



## DUBAI HEAD OFFICE

### Factory & Warehouse:

- +971 4 447 4117
- info@chsdx.com
- Dubai Industrial City (DIC)  
United Arab Emirates.

## KSA OFFICE

- +966 56 8284 419
- infoksa@chsdx.com
- Building – Port Stores 6614,  
Office-01, Prince Turkey St.,  
Al Khobar 34423,  
Kingdom of Saudi Arabia



Follow us:

creativehousescaffolding